

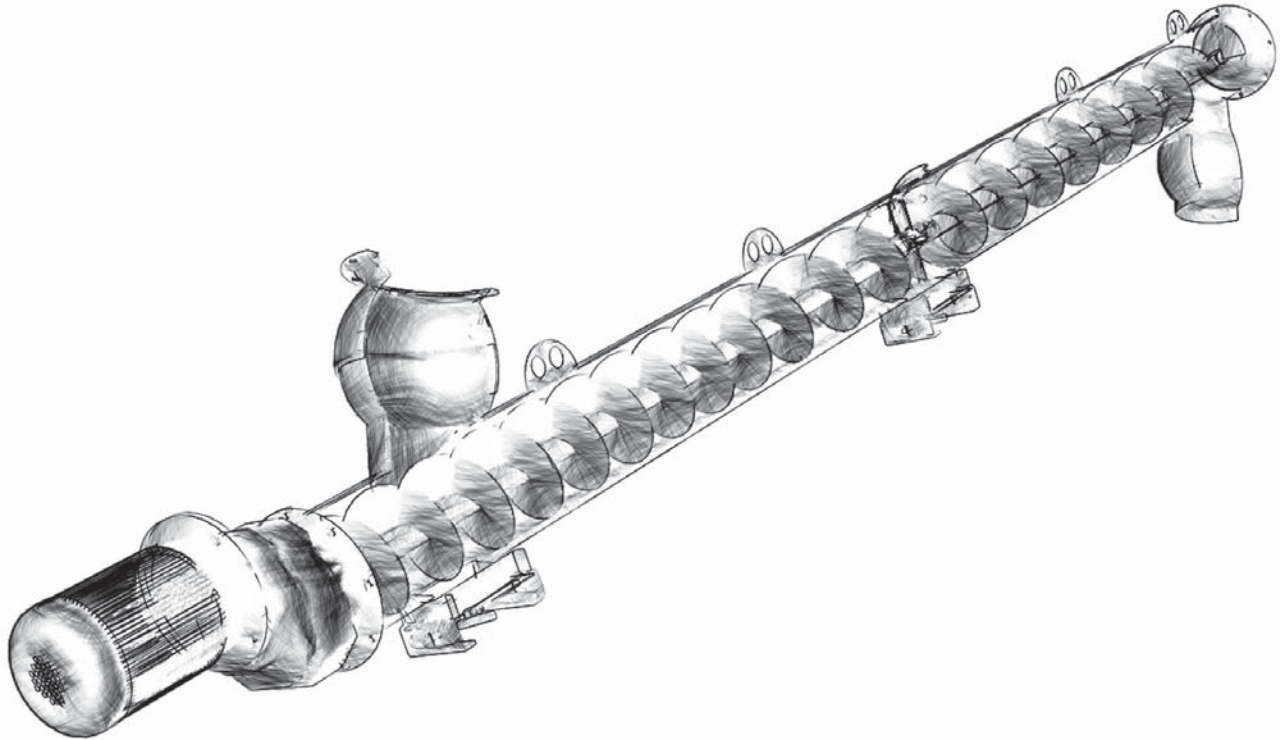

WAM[®] Inc.



ES

**TUBULAR
CEMENT - FLYASH
SCREW CONVEYORS**



All the products described in this catalogue are manufactured according to **WAMGROUP S.p.A. Quality System procedures**. The Company's Quality System, certified in July 1994 according to International Standards **UNI EN ISO 9002** and extended to the latest release of **UNI EN ISO 9001**, ensures that the entire production process, starting from the processing of the order to the technical service after delivery, is carried out in a controlled manner that guarantees the quality standard of the product.

**This publication cancels and replaces any previous edition and revision.
We reserve the right to implement modifications without notice.
This catalogue cannot be reproduced, even partially, without prior consent.**



TUBULAR CEMENT SCREWS CONVEYORS

Page

Standard Installation.....	3
Inquiry Form.....	4
Wam Standard Cement Screw.....	5
Dimensions Gearboxes.....	6
Standard Round Inlet / Outlet Spout XBC.....	7
Optionals - Universal Inlet and Outlet Spout.....	8
Modular Code Key.....	9 < 10

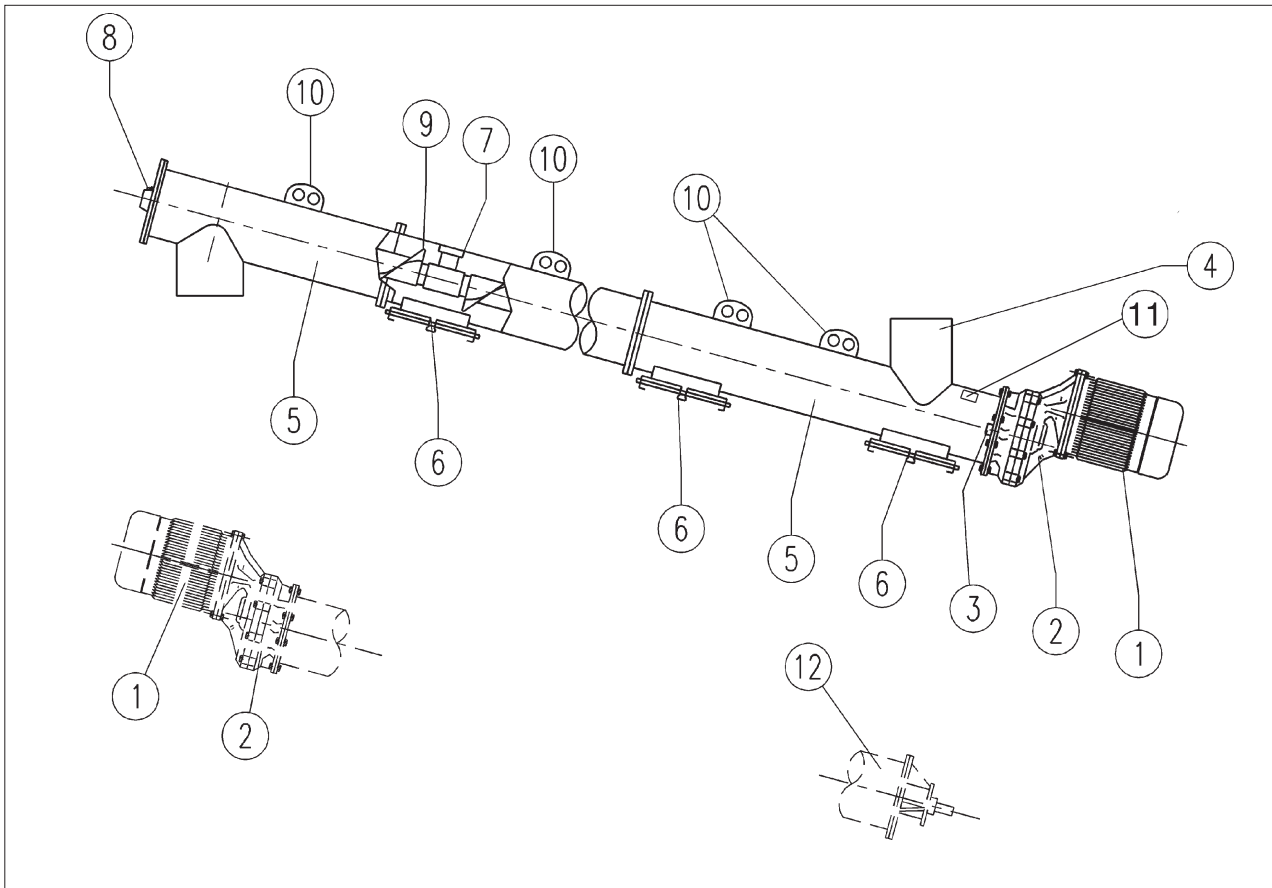

1	Electric motor
2	(Compact) Gear reducer
3	Gear reducer shaft sealing
4	Inlet spout
5	Tubular housing
6	Inspection hatch
7	Intermediate bearing
8	Outlet end bearing
9	Spiral
10	Lifting eye
11	Serial number
12	Inlet end bearing
13	Outlet spout

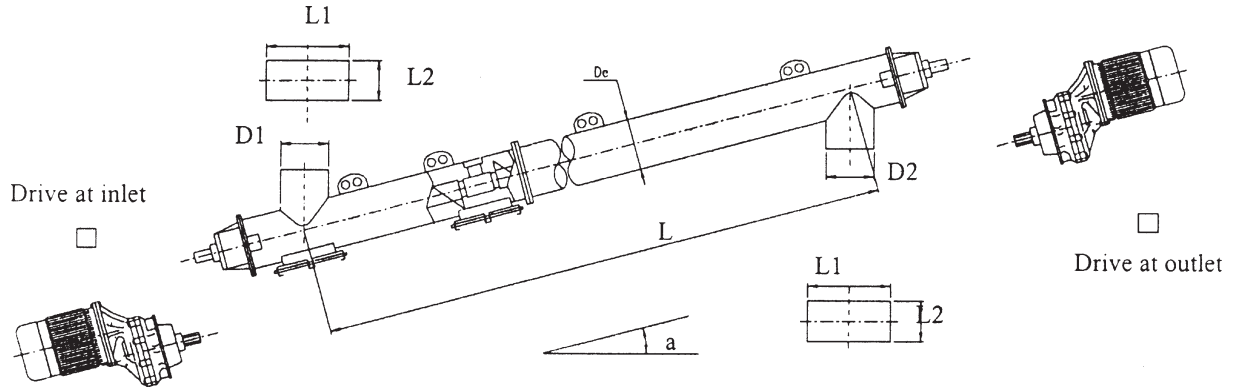
INSTALLATION / DIMENSIONS

 Conveyor's Diameter **De** =

 Length (Center inlet to center outlet) **L** =

 Angle of Inclination **a** =

 Inlet Diameter (Circular) **D1** =

 Outlet Diameter (Circular) **D2** =

OPTIONAL INLETS & OUTLETS

 Inlet Swivel Spout.....

Inlet Swivel Spout Diameter.....

 Outlet Swivel Spout.....

Outlet Swivel Spout Diameter.....

Square Inlet (Dimensions: L1 x L2).....

Square Outlet (Dimensions: L1 x L2).....

OPERATION

Indoor or outdoor installation.....

 Environmental temperature..... **F**

 Continuous.....

 Intermediate.....

Working hours/day.....

Working hours/years.....

Start/stops per hour.....

SEALS & HANGER BEARINGS

 Special seals *yes no

 Special hanger bearings *yes no

* Specify use

MATERIAL SPECIFICATIONS

 Extracting - Flood Fed.....

 Conveying - Controlled Fed.....

Product.....

Bulk density..... Lbs/CF

Mesh Particle Size.....

Special characteristics.....

Product Moisture..... %

CEMA code.....

Feed rate..... Lb/min

Feed rate..... CF/Hr

MOTOR INFORMATION

Voltage..... Cycles..... Hz

NEMA ratings..... RPM.....

 Direct drive..... *yes no

DRIVE LOCATION

 Inlet..... Outlet.....
FINISHING

Standard..... 1 coat of primer & 1 coat of paint

Color.....

CONSTRUCTION MATERIAL

 Carbon steel construction.....

 Stainless Steel 304 construction (TU only).....



ES - TUBULAR CEMENT SCREWS CONVEYORS

WAM STANDARD CEMENT SCREW

*CAPACITY	233 LBS / MIN	1050 LBS / MIN	2800 LBS / MIN	4000 LBS / MIN	6000 LBS / MIN	7000 LBS / MIN
DIAMETER	4" Dia (114 ESO)	6" Dia (168 ES1)	8" Dia (219 ES3)	10" Dia (273 ES4)	12" Dia (323 ES5)	12" Dia (323 EX5)
FEET / METERS						
3.28 FT / 1M	M17 1.5kW 2HP	M17 2.2kW 3HP	M12 5.5kW 7.5HP	M12 5.5kW 7.5HP	M11 11kW 15HP	M11 15kW 20HP
6.56 FT / 2M	M17 1.5kW 2HP	M17 3.7kW 5HP	M12 5.5kW 7.5HP	M12 7.5kW 10HP	M11 11kW 15HP	M11 15kW 20HP
9.84 FT / 3M	M17 1.5kW 2HP	M17 3.7kW 5HP	M12 5.5kW 7.5HP	M12 7.5kW 10HP	M11 11kW 15HP	M11 15kW 20HP
13.12 FT / 4M	M17 1.5kW 2HP	M17 3.7kW 5HP	M12 7.5kW 10HP	M12 7.5kW 10HP	M11 15kW 20HP	M15 22kW 30HP
16.40 FT / 5M	M17 1.5kW 2HP	M12 5.5kW 7.5HP	M12 7.5kW 10HP	M11 11kW 15HP	M11 15kW 20HP	M15 22kW 30HP
19.70 FT / 6M	M17 1.5kW 2HP	M12 5.5kW 7.5HP	M12 7.5kW 10HP	M11 11kW 15HP	M15 18.5kW 25HP	M15 30kW 40HP
23.00 FT / 7M	M17 2.2kW 3HP	M12 5.5kW 7.5HP	M11 11kW 15HP	M11 15kW 20HP	M15 22kW 30HP	M15 30kW 40HP
26.25 FT / 8M	M17 2.2kW 3HP	M12 5.5kW 7.5HP	M11 11kW 15HP	M11 15kW 20HP	M15 22kW 30HP	
29.50 FT / 9M	M17 2.2kW 3HP	M12 5.5kW 7.5HP	M11 11kW 15HP	M15 18.5kW 25HP	M15 30kW 40HP	
32.80 FT / 10M	M17 3.7kW 5HP	M12 7.5kW 10HP	M11 11kW 15HP	M15 18.5kW 25HP	M15 30kW 40HP	
36.10 FT / 11M	M17 3.7kW 5HP	M12 7.5kW 10HP	M11 15kW 20HP	M15 18.5kW 25HP		
39.40 FT / 12M	M17 3.7kW 5HP	M12 7.5kW 10HP	M11 15kW 20HP	M15 18.5kW 25HP		
42.65 FT / 13M	M17 3.7kW 5HP	M12 7.5kW 10HP	M11 15kW 20HP	M15 18.5kW 25HP		

MATERIAL DESCRIPTION	LOOSE BULK DENSITY #/FT. ³	CEMA MATERIAL CODE
Cement, Aerated (Portland)	60-75	A10015M
Flyash	30-45	A4036M

IESI SCREW CONVEYORS ARE SPECIFICALLY DESIGNED FOR CEMENT, FLYASH, AND SIMILAR PRODUCTS

CODE BREAKDOWN

ES.(external diameter in mm).(length in meters).(motor size)

EXAMPLE: ES.219.7.1100 = 8" diameter - 7 meters long - 11.0 kW (15HP)

*** NOTE:** THE CAPACITY REFERS TO PORTLAND CEMENT AT 70 LBS/CF
FLYASH CAPACITY IS APPROXIMATELY ONE HALF OF ABOVE CAPACITIES

OPTION: NON STANDARD CAPACITIES ARE AVAILABLE, CONTACT OUR **TECHNICAL DEPARTMENT**

NOTE: LENGTH IS MEASURED FROM CENTER OF INLET TO CENTER OF OUTLET

DIMENSIONS

Unit	mm					Inches				
∅ S	4"	6"	8"	10"	12"	4"	6"	8"	10"	12"
	114	168	219	273	323	114	168	219	273	323
A	56	40	40	40	40	2.2	1.57	1.57	1.57	1.57
∅B										
C	120	140	160	160	220	4.72	5.51	6.30	7.09	8.66
∅D										
E	140	160	180	220	220	5.51	6.30	7.09	8.66	8.66
L										
∅F	190	250	275	330	405	7.48	9.84	10.83	12.99	15.94
G										
H										
M										
N	131	173	173	173	173	5.16	6.81	6.81	6.81	6.81

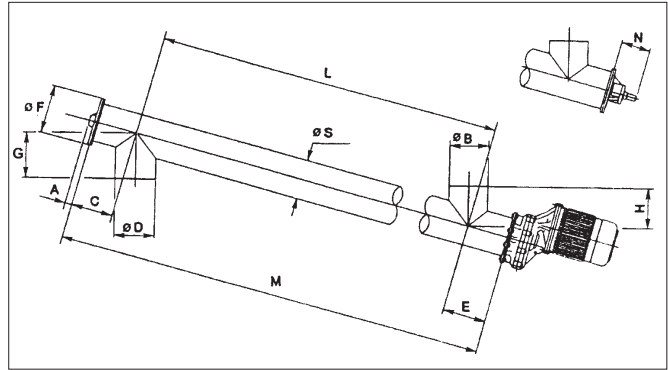

GEARBOXES

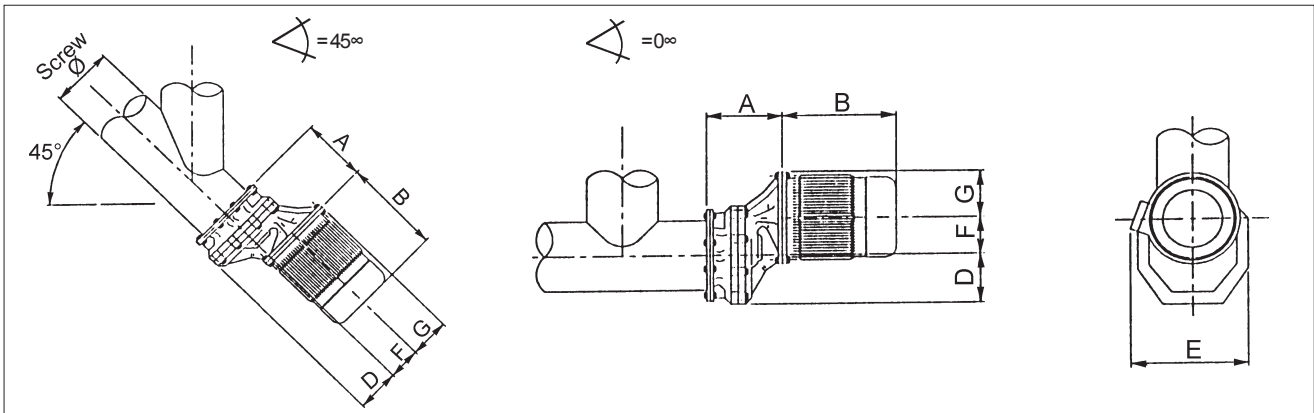

M17		mm						Inches					
HP	kW	A	B	D	E	F	G	A	B	D	E	F	G
2	1.5	154	278	100	250	83	100	6.06	10.9	3.94	9.84	3.27	3.94
3	2.2	164	302	100	270	83	125	6.45	11.9	3.94	10.6	3.27	4.92
5	4	164	334	100	270	83	125	6.45	13.1	3.94	10.6	3.27	4.92
7.5	5.5	199	371	100	322	83	150	7.83	14.6	3.94	12.7	3.27	5.90

M12		mm						Inches					
HP	kW	A	B	D	E	F	G	A	B	D	E	F	G
5.5	4.0	202	334	106	270	100	125	7.95	13.1	4.17	10.6	3.94	4.92
7.5	5.5	223	371	106	322	100	150	8.78	14.5	4.17	12.7	3.94	5.91
10	7.5	223	409	106	322	100	150	8.78	16.1	4.17	12.7	3.94	5.91
15	11	223	485	106	413	100	175	9.56	19.1	4.17	16.3	3.94	6.89

M11		mm						Inches					
HP	kW	A	B	D	E	F	G	A	B	D	E	F	G
7.5	5.5	242	371	130	322	130	150	9.53	14.6	5.12	12.7	5.12	5.91
10	7.5	242	409	130	322	130	150	9.53	16.1	5.12	12.7	5.12	5.91
15	11	272	485	130	405	130	175	10.7	19.1	5.12	15.9	5.12	6.89
20	15	272	529	130	405	130	175	10.7	20.8	5.12	15.9	5.12	6.89

M15		mm						Inches					
HP	kW	A	B	D	E	F	G	A	B	D	E	F	G
15	11	263	485	200	405	162	175	10.4	19.1	7.9	15.9	6.38	6.89
20	15	263	529	200	405	162	175	10.4	20.8	7.9	15.9	6.38	6.89
25	18.5	263	543	200	421	162	175	10.4	21.4	7.9	15.9	6.38	6.89
30	22	263	619	200	421	162	175	10.4	24.4	7.9	15.9	6.38	6.89
40	30	263	665	200	505	162	200	10.4	26.2	7.9	19.8	6.38	7.87

NEMA MOTORS

kW	Hp	IEC	MOTORS	NEMA	MOTORS	RPM
		Size	Flange	Size	Flange	
1.5	2	90	D	145	C	1800
2.2	3	100	D	182	C	1800
3.7	5	112	D	184	C	1800
5.5	7.5	132S	D	213	C	1800
7.5	10	132M	D	215	C	1800
11	15	160M	D	254	C	1800
15	20	160L	D	256	C	1800
18.5	25	180M	D	282	C	1800
22	30	180L	D	284	C	1800
30	40	200	D	324	C	1800

STANDARD ROUND INLET / OUTLET SPOUT XBC

Code			X		B		C		D		A		C		α°		1
------	--	--	---	--	---	--	---	--	---	--	---	--	---	--	----------------	--	---

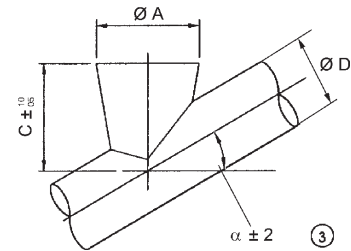
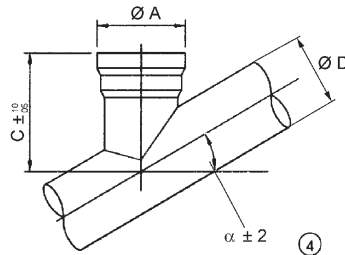
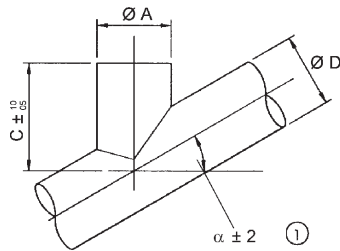

Ø D	Ø A	Code	*	"C" depending on α° - F - T																kg				
				0°		5°		10°		15°		20°		25°		30°		35°			40°		45°	
				F	T	F	T	F	T	F	T	F	T	F	T	F	T	F	T		F	T	F	T
114	§ 114	XBC114114...1	1	120	120	120	120	120	120	120	170	170	170	220	2									
	168	XBC114168...1	3	170	220	170	220	170	220	170	220	170	220	170	220	220	220	220	220	220	220	220	2	
	193	XBC114193...1	3	245	295	245	295	245	295	245	295	245	295	245	295	245	295	245	295	245	295	245	295	3
	219	XBC114219...1	3	225	275	225	275	225	275	225	275	225	275	225	275	225	275	225#	275	225#	275	225#	275	3
168	§ 168	XBC139168...1	1	175	175	175	175	175	175	175	175	225	225	250	3									
	193	XBC168193...1	4	230	230	230	230	230	290	290	290	350	350	5										
	219	XBC168219...1	4	230	230	230	230	230	290	290	290	350	350	8										
	273	XBC168273...1	3	325	375	325	375	325	375	325	375	325	375	325	375	325	375	325	375	325	375	375	5	
219	193	XBC219193...1	1	205	205	205	205	205	205	255	255	305	305	5										
	§ 219	XBC219219...1	1	205	205	205	205	255	255	395	395	395	395	8										
	273	XBC219273...1	4	280	280	280	280	280	355	335	335	405	405	10										
	323	XBC219323...1	3	320	370	320	370	320	370	320	370	320	370	320	370	320	370	370	370#	370	370	7		
273	219	XBC273219...1	1	260	260	260	260	260	260	310	455	455	455	8										
	§ 273	XBC273273...1	1	250	250	250	300	300	300	300	300	400	400	400#400	10									
	323	XBC273323...1	4	315	315	315	315	315	385	385	385	480	480	13										
323	273	XBC323273...1	1	260	260	260	260	360	360	360	360	460	460	10										
	§ 323	XBC323323...1	1	300	300	300	300	300	360	360	360	460	460	13										

F = with flange

T = with beaded edge

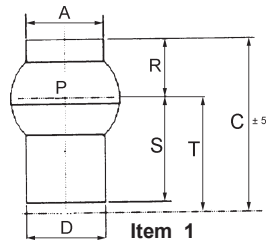
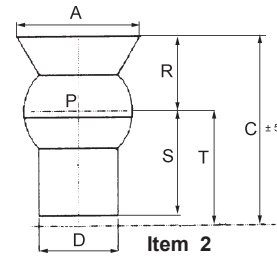

INLET

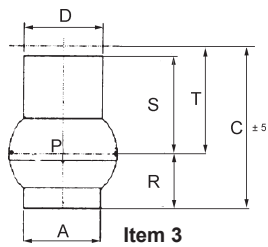
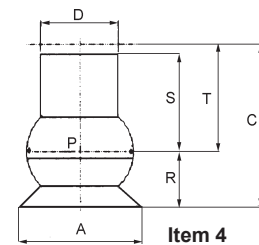
Code		Pos.	D	A	C	R	S	T	kg		
XBA 168	168	390	1	1	168	168	390	135	235	253	7
	193	385	1	2	168	193	385	135	235	253	7
	219	380	1	2	168	219	380	125	235	253	7
	273	425	1	2	168	273	425	175	235	253	8.8
	323	470	1	2	168	323	470	220	235	253	9.6
XBA 219	219	455	1	1	219	219	455	150	285	305	10.7
	273	445	1	2	219	273	445	140	285	305	10.7
	323	490	1	2	219	323	490	185	285	305	13.3
XBA 273	273	545	1	1	273	273	545	175	345	370	15.9
	323	540	1	2	273	323	540	170	345	370	15.9
XBA 323	323	575	1	1	323	323	590	175	390	415	20.7

OUTLET

Code		Pos.	D	A	C	R	S	T	kg		
XBB 168	168	390	1	3	168	168	385	135	235	253	7
	219	380	1	4	168	219	380	130	235	253	7
XBB 219	219	455	1	3	219	219	455	150	285	305	10.7
	273	445	1	4	219	273	445	140	285	305	10.7
XBB 273	273	545	1	3	273	273	545	175	345	370	15.9
	323	540	1	4	273	323	540	170	345	370	15.9
XBB 323	323	595	1	3	323	323	595	175	390	419	20.7

MODULAR CODE KEY

 1st GROUP
 STRUCTURE

ES ESL ESV

--	--	--	--	--	--	--	--	--	--	--	--	--	--

Pipe diameter

 114 = 4"
 168 = 6"
 219 = 8"
 273 = 10"
 323 = 12"

mm

Inlet-outlet length

 114
 168 - 273
 323

cm

Inlet type

 A = Universal
 C = Circular
 + = None or special

Inlet diameter

mm

Inlet height

mm

Outlet type

 B = Universal
 C = Circular
 + = None or speciale

Outlet diameter

mm

Outlet height

mm

Inclination

degrees

MODULAR CODE KEY

 2nd GROUP
DRIVE UNIT



Gear reducer
M11 - M12 - M15 - M17 - M19 - L19 - L17

Gear ratio
05 - 07 - 10

Inst. drive power
01 10 - 01 50 - 02 20 - 03 00 - 04 00 - 05 00
07 50 - 09 20 - 11 00 - 15 00 - 18 50 - 22 00

Nbr of poles
48 = 4/8
40 = 4

Voltage supply
208 V
230 V
460 V
575 V

Cycles
50 = 50 Hz
60 = 60 Hz
++ = non-WAM

Drive position
C = Inlet end
T = Outlet end

ES Code (mm)	Tube y Nom.	Length Range		Motor Range	Standard Feed Rate Cement		
		feet	meters		lbs/min	ton/hour	
ES.114	4f	3-45	1-15	1.5-4	2.5-5.5	233	7
ES.168	6f	3-45	1-15	2.2-7.5	3-10	1050	29
ES.219	8f	3-45	1-15	5.5-15	7.5-20	2800	80
ES.273	10f	3-45	1-15	5.5-22	7.5-30	4000	115
ES.323	12f	3-45	1-15	11-22	15-30	6000	190
ES.323	12f	3-23	1-7	22-30	30-40	7000	220

Code Breakdown
 ES (external y in mm). (length in meters). (motor size)
 Example: ES.219.7.1100 = 8f diameter - 7meters long - 11.0 KW (15.0 Hp)

Portland Cement 70 lbs / cf
 Swivel Spout - Ranges from 6f - 12f for inlet or discharge

Standard Screw

- Motor
- Gearbox
- Inlet & discharge with same diameter as trough tube
- Motor and gearbox on inlet side

Options

- Drive on discharge end
- Heavy-duty hanger bearings
- Swivel spout - Ranges from 6f-12f on top and/or bottom

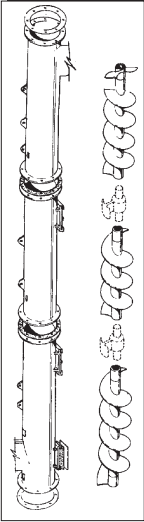

MODULAR CONSTRUCTION

- Ease of shipping
- Pre-assembled

SCREW CONVEYORS ARE ESPECIALLY DESIGNED FOR CEMENT AND FLYASH

INTERMEDIATE BEARING

- Engineered for minimum product obstruction
- Low maintenance
- Transmits none torque
- Better alignment

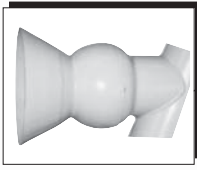
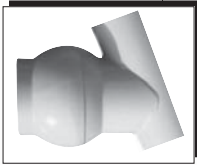
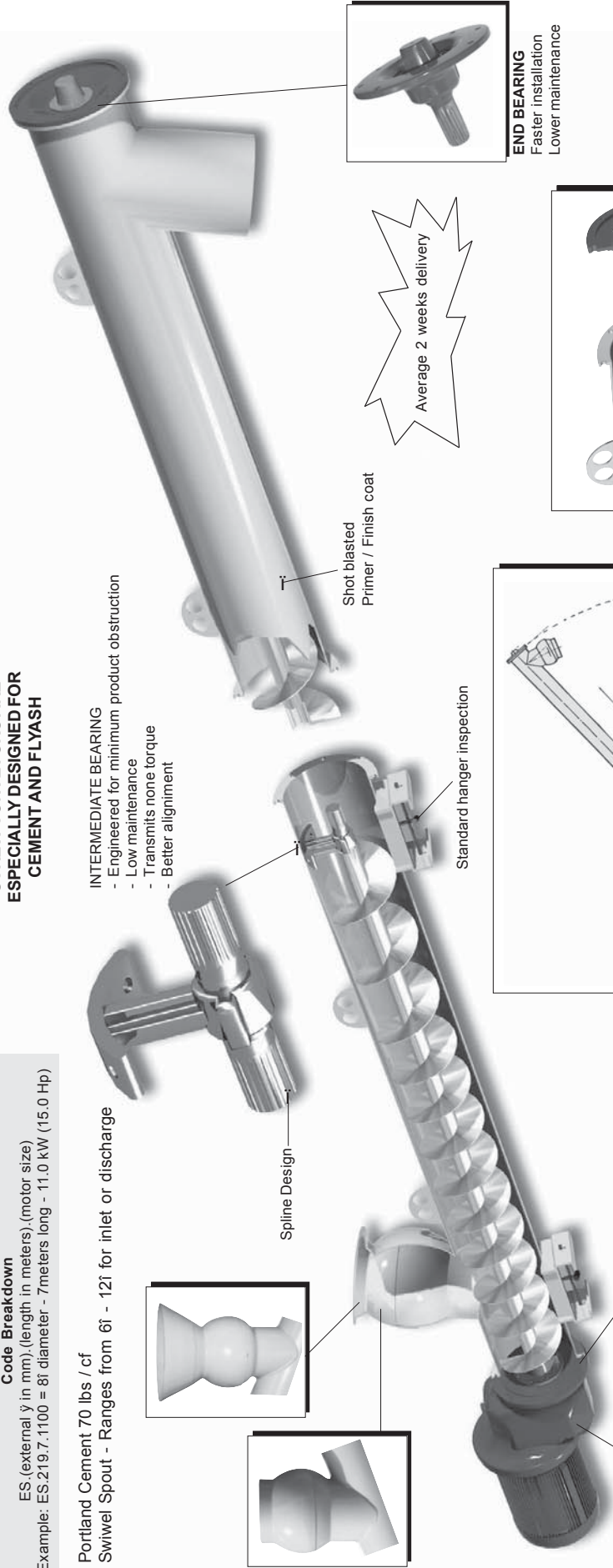

Shot blasted Primer / Finish coat

Average 2 weeks delivery



END BEARING
 Faster installation
 Lower maintenance

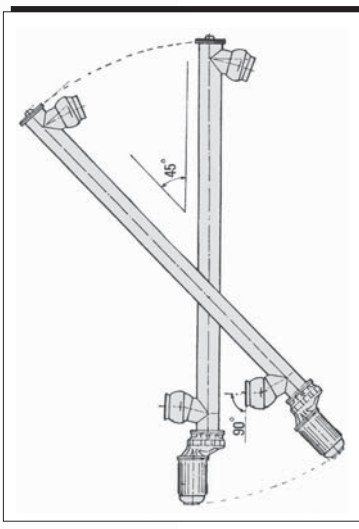

SWIVEL SPOUT ADJUSTABLE INCLINATION
 Flexible tolerance - Allow for easy field installation

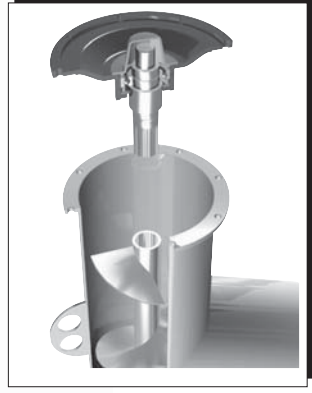

SPLINED COUPLING
 Faster installation - Lower maintenance

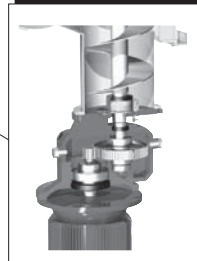

GEARBOX
 Heavy-duty construction - Oversized

FEATURES	FUNCTION	BENEFIT
<ul style="list-style-type: none"> ✓ Modular construction 	<ul style="list-style-type: none"> ✓ EASES THE ASSEMBLING 	<p><i>Average 2 weeks delivery</i></p> <ul style="list-style-type: none"> Fast assembly Rigid construction Ease of shipping
<ul style="list-style-type: none"> ✓ All connections splined 	<p>EASES THE <ul style="list-style-type: none"> ✓ ASSEMBLING/DISASSEMBLING AND INSTALLATION </p>	<ul style="list-style-type: none"> Higher strength than standard competitor bolted shafts
<ul style="list-style-type: none"> ✓ Heavy-duty gearbox 	<ul style="list-style-type: none"> ✓ DIRECT DRIVE 	<ul style="list-style-type: none"> No belts No slippage Lower maintenance
<ul style="list-style-type: none"> ✓ Special designed intermediate bearings 	<ul style="list-style-type: none"> ✓ REDUCES PRODUCT OBSTRUCTION 	<ul style="list-style-type: none"> Higher loads Better alignment Less play
<ul style="list-style-type: none"> ✓ Modular Construction 	<ul style="list-style-type: none"> ✓ ADJUSTABLE ANGLE OF INCLINATION 	<ul style="list-style-type: none"> Allows easy adjustments during installation

COMPONENTS AND ACCESSORIES SECTION

Page

Outlet End Bearing XTA.....	14
Inlet End Bearing XTB.....	15
Intermediate Bearing XLR.....	16
Optional Heavy Duty Hanger Assembly XLY.....	17
Optionals - Flanges / Adjustable Support XJX.....	18

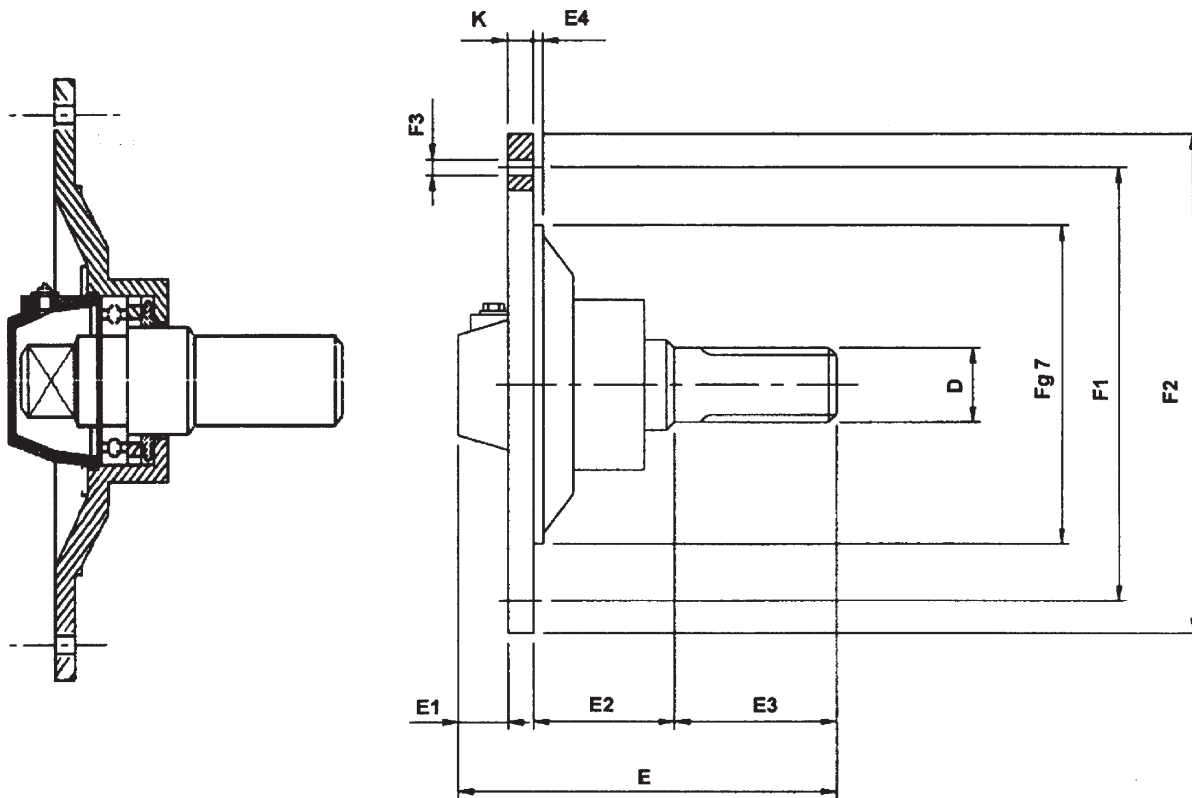
**OUTLET END BEARING
XTA**

ÿ Feeder
0 = 114
1 = 168
2 = 193
3 = 219
4 = 273
5 = 323

X	T	A	0	0	E	S	A	0	1
---	---	---	---	---	---	---	---	---	---

Code	DIN 5482 Ø D	E	E1	E2	E3	E4	Ø F	Ø F1	Ø F2	F3		K	kg	Bearing
										Ø	N°			
XTA00ES0A01	28x25	175	50	54	65	2	148	170	190	M8	4	6	3	6006 - 2RS
XTA00ES1A01	40x36	197.5	32	72.5	85	3	162	220	250	M10	8	8	7	6008 - 2RS
XTA00ES2A01	40x36	197.5	32	72.5	85	3	186	220	250	M10	8	8	7	6008 - 2RS
XTA00ES3A01	40x36	197.5	32	72.5	85	3	210	250	275	M10	8	8	7.5	6008 - 2RS
XTA00ES4A01	40x36	197.5	32	72.5	85	3	265	305	330	M10	8	8	9.5	6008 - 2RS
XTA00ES5A01	40x36	197.5	26	72.5	85	4	315	370	405	M10	8	14	15	6008 - 2RS

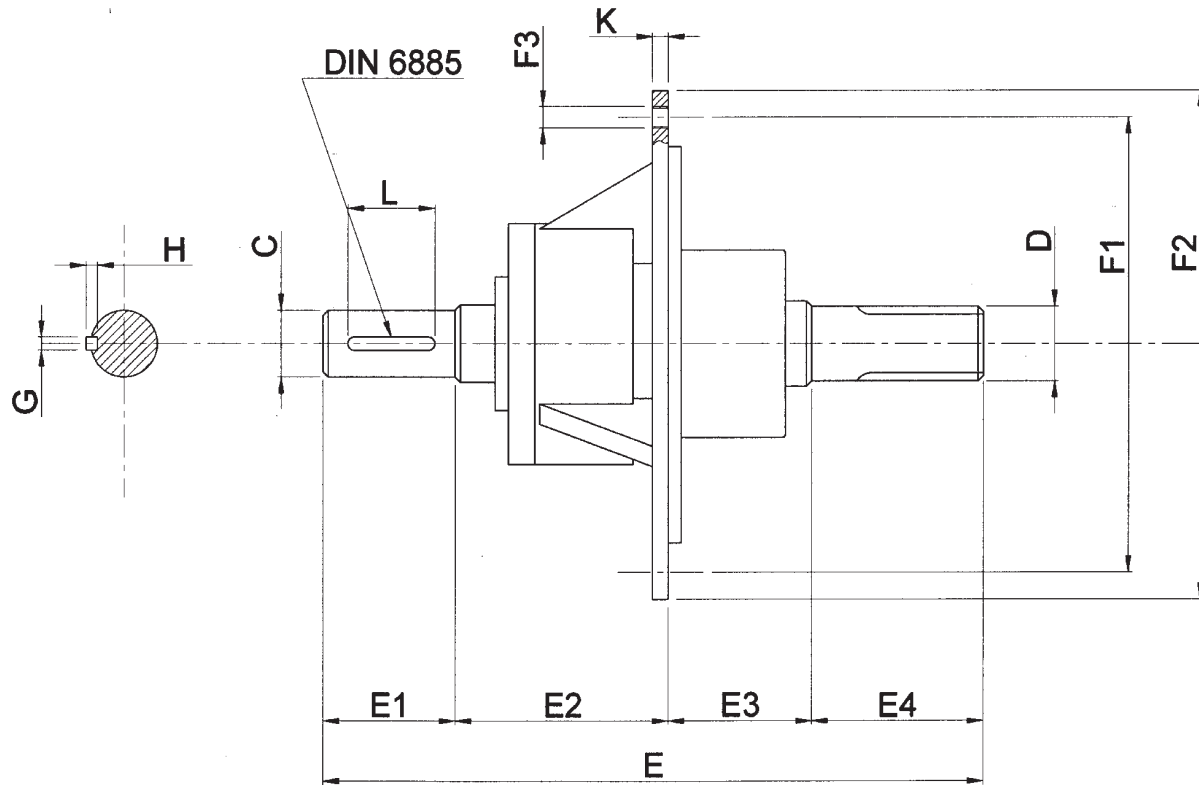

ÿ Feeder
 0 = 114
 1 = 168
 3 = 219
 4 = 273
 5 = 323

X T B E S B 1 2

Code	UNI 6397 Ø C	DIN 5482 Ø D	E	E1	E2	E3	E4	E5	E6	Ø F	Ø F1	Ø F2	F3		K	GxHxL DIN 6885	kg	Bearing		Grease kg
													Ø	N°				rad.	ax.	
XTB25ES0B12	25	28x25	250	50	81	54	65	2	2	148	170	190	M8	4	12	8x7x45	6	60065	1106	0.06
XTB35ES1B12	35	40x36	330	55	117.5	72.5	85	2	3	162	220	250	M10	8	14	10x8x50	14	62085	1108	0.08
XTB35ES2B12	35	40x36	330	55	117.5	72.5	85	2	3	186	220	250	M10	8	14	10x8x50	14	62085	1108	0.08
XTB35ES3B12	35	40x36	330	55	117.5	72.5	85	2	3	210	250	275	M10	8	15	10x8x50	16.5	63085	1208	0.09
XTB35ES4B12	35	40x36	330	55	117.5	72.5	85	2	3	265	305	330	M10	8	15	10x8x50	19.7	63085	1208	0.09
XTB35ES5B12	35	40x36	330	55	117.5	72.5	85	2	4	315	370	405	M10	8	15	10x8x50	25	63085	1208	0.09

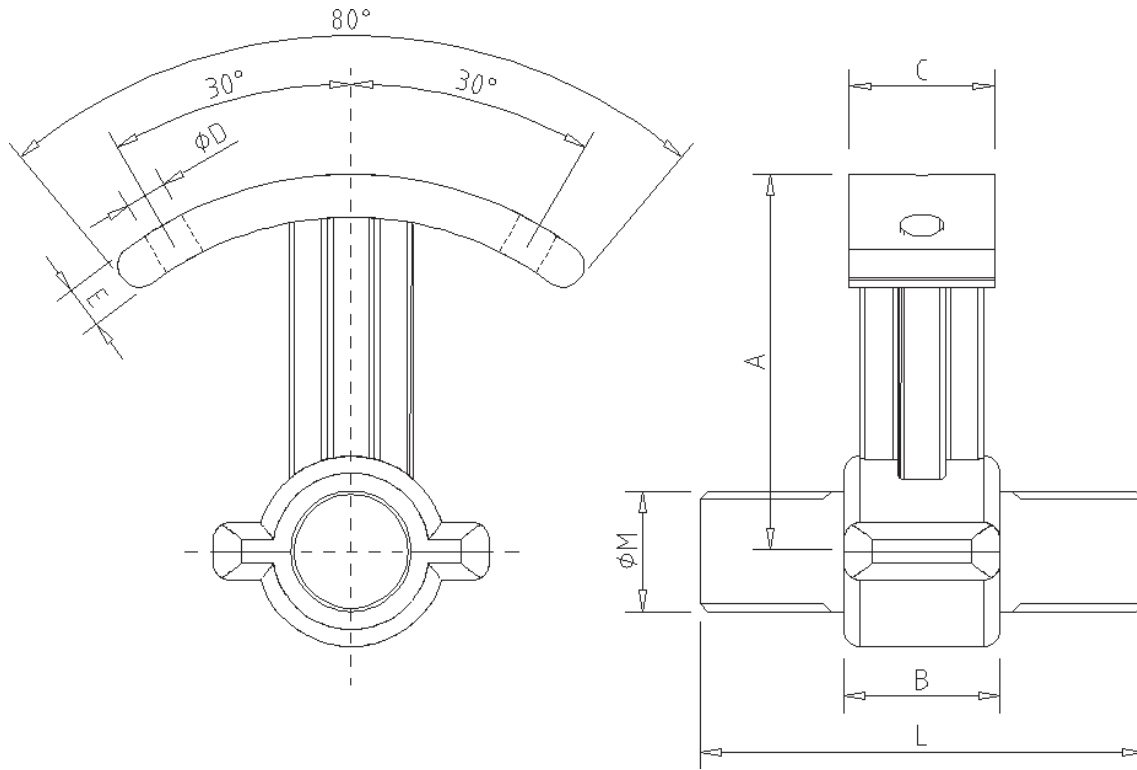

ÿ Feeder
010 = 114
015 = 168
017 = 193
020 = 219
025 = 273
030 = 323

X	L	R			B				T	4	4
---	---	---	--	--	---	--	--	--	---	---	---

028 = ÿ114
040 = ÿ168 - 219 - 273 - 323

Code	Ø Shaft	Ø Feeder	A	B	C	Ø D	E	L	Ø M DIN 5482	Kg
XLR028B010T44	028	114	54	35	30	M10	8	170	28x25	1.7
XLR028B012T44	028	139	66.5	35	30	M10	10	170	28x25	1.8
XLR040B015T44	040	168	80	55	51	M14	15	245	40x36	3.5
XLR040B017T44	040	193	92.5	55	51	M14	15	245	40x36	3.9
XLR040B020T44	040	219	105.5	55	51	M14	15	245	40x36	4.3
XLR040B025T44	040	273	132.5	55	51	M14	15	245	40x36	4.5
XLR040B030T44	040	323	157.5	55	51	M14	15	245	40x36	5

CAST ALUMINIUM HANGER STRUCTURE WITH INCORPORATED SELF-LUBRICATING BUSH

The hanger is made up in two parts to enable dismantling without removing the spiral.

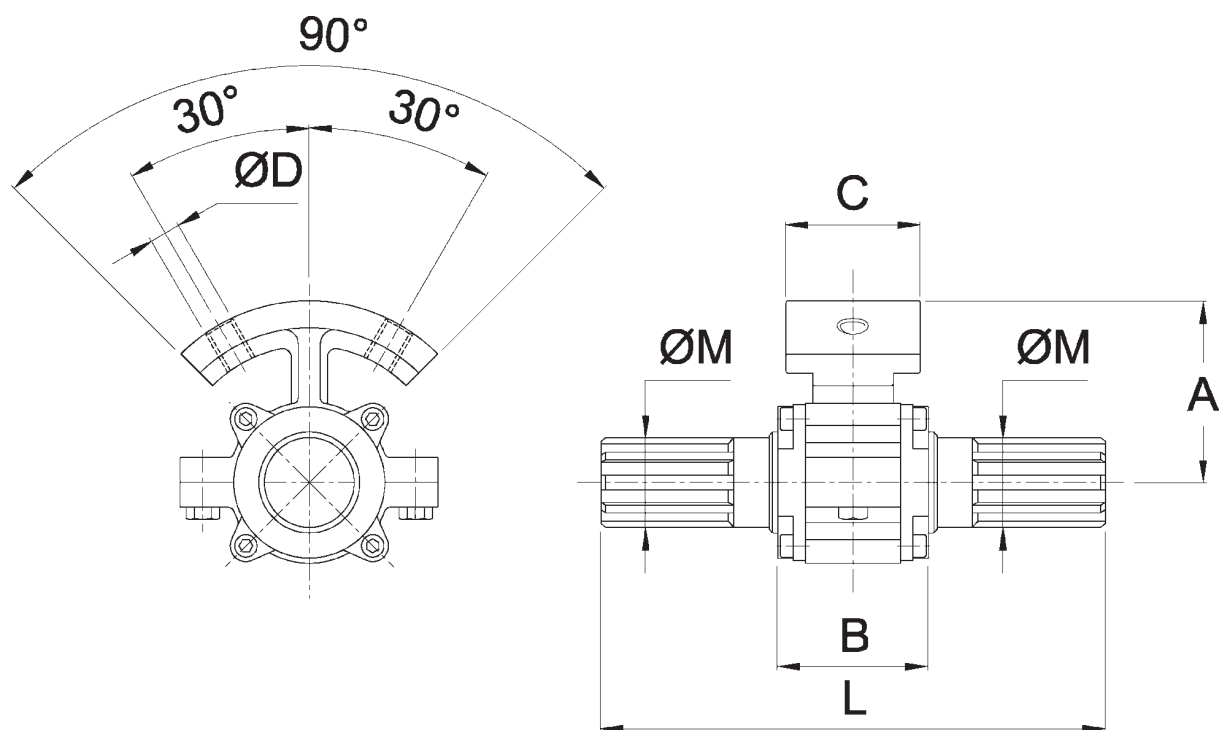

Code	Ø Shaft	Ø Feeder	A	B	C	Ø D	L	Ø M DIN 5482	kg
XLY045H015T11	45	168	80	75	62	M14	225	40 x 36	4
XLY045H017T11	45	193	92.5	75	62	M14	225	40 x 36	4.2
XLY045H020T11	45	219	105.5	75	62	M14	225	40 x 36	4.5
XLY045H025T11	45	273	132.5	75	62	M14	225	40 x 36	4.7
XLY045H030T11	45	323	157.5	75	62	M14	225	40 x 36	5

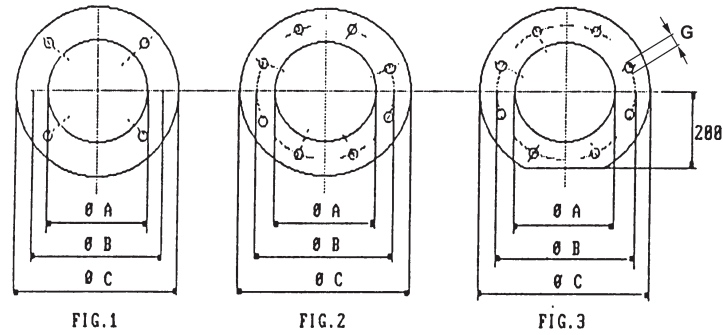
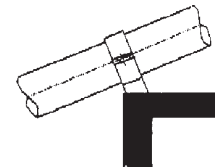

Fig.	Code	Ø A	Ø B	Ø C	G		Thickness	Type of VFS Valve	kg
					N°	Ø			
1	XKF291	141	180	220	4	13.5	6	100	1
1	XKF301	116	180	220	4	14	6	100	1.5
1	XKF311	168	200	228	4	14	6	150	1.0
1	XKF321	193	250	278	4	14	6	200	1.7
2	XKF331	219	250	278	8	14	6	200	1.3
2	XKF341	273	300	328	8	14	6	250	1.5
2	XKF351	323	350	378	8	14	6	300	1.7
3	XKF361	323	375	440	8	14	6	300	4.0
2	XKF371	357	400	440	8	14	6	350	3.0
2	XKF381	408	470	530	8	14	6	400	5.0

OPTION ADJUSTABLE SUPPORT

Example of application



Mounted on framework

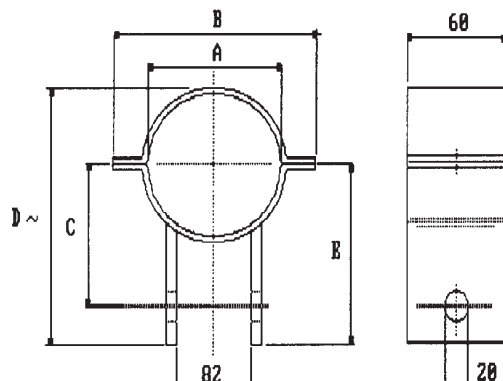

Code	A	B	C	D	E	kg
XJX2191	219	320	165	305	190	2.50
XJX2731	273	375	190	355	215	2.80
XJX3231	323	425	215	405	240	3.10

Adjustable supports are strong pipe clamps used for fixing of the feeder to an existing structure and to prevent vibrations and flections. They can be mounted at any point of the pipe section, as they are made up of two half-rings that are bolted together.

Finishing: galvanized



OPERATION AND MAINTENANCE

Page

Assembly Instructions When Using WAM^Æ Butterfly Valve.....	20
Replacement of Hanger Bearing.....	21
Operation and Maintenance.....	22
Operation and Maintenance Lubrification.....	23

ASSEMBLY INSTRUCTIONS WHEN USING WAM[®]BUTTERFLY VALVE

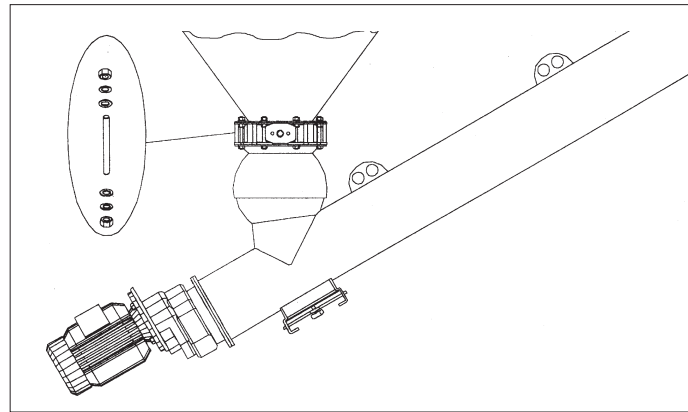

- 1) The VFS-type valves made of aluminium alloy are not designed to bear the weight of equipment installed below (e.g. screw feeders, belt conveyors, vibratory feeders etc.).
- 2) To fix the valve, only use stud bolts that are long enough to pass through the upper connecting flange, the valve itself as well as the lower connecting flange, forming a sandwich. Screw on the nuts firmly but not excessively. The inside nuts have no weight-bearing function. They only serve to secure the valve when the feeder installed below is stripped down.
- 3) Apply a thin layer of liquid seal before fitting the valve to the connecting flange.
- 4) Close the valve only when material is flowing.
- 5) Clean the valve regularly with either air or water. This is particularly important if the material handled tends to compact or to solidify due to longer shutdown periods.
- 6) Operating temperature <math>< 80^{\circ}\text{C}</math>.
- 7) The material weight resting on the disc must never be greater than its maximum static torque. As it is difficult to calculate this weight exactly due to varying material properties, as rule of thumb, one may consider there are no problems with bulk densities <math>< 1.3 \text{ t/m}^3</math> in standard hoppers and silos
- 8) Refer to assembly instructions on WAM[®] actuators included in each package.

REPLACEMENT OF SEALS IN DRIVE HEAD AND IN END BEARING ASSEMBLY

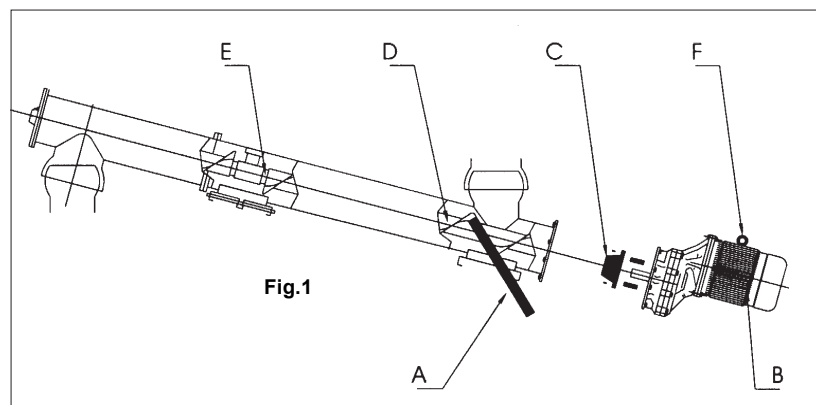

Referring to **Fig.1** carry out the following steps:

- 1) Close silo valve.
- 2) Empty screw feeder.
- 3) Disconnect electric motor from mains.
- 4) Open inspection hatches.
- 5) Prevent the inlet screw (D) from sliding out by introducing a plank (A) into the inlet hatch ensuring plank firmly locks in.
- 6) Ensure eyebolt (F) of electric motor is tightly screwed on.
- 7) Fix the lifting device to the eyebolt (F).
- 8) Remove reducer flange bolts and remove gear motor (B).
- 9) Replace seals (C) with new ones.
- 10) Reassemble parts proceed-ing in the opposite way as described.

The same operations apply also if drive unit is at outlet end.
And if the sealing of the end bearing has to be substituted

REPLACEMENT OF HANGER BEARING

With reference to **Fig. 2** carry out the following steps:

- 1) Open inspection hatch beneath the bearing to be replaced.
- 2) Remove bolts that fasten the two bearing halves.
- 3) Lower bearing half is now free. Remove external hanger bolts and turn upper hanger half until it can be extracted through the hatch.

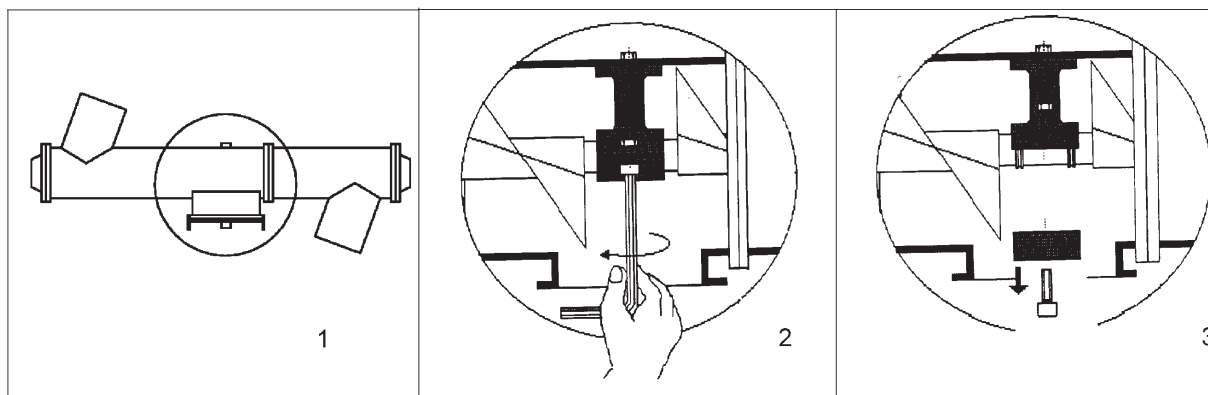
**REPLACEMENT OF HANGER BEARING
(INCLUDING SHAFT)**

In addition to **Fig.1**, as well as to instructions under reference **Fig.2** proceed as follows:

- 4) Carefully loosen plank (A)
- 5) Gently lower inlet spiral (D) until shaft (E) is free.
- 6) Replace shaft (E).

For reassembly proceed the opposite way.

If only the slide bushes must be replaced the above-mentioned steps do not have to be carried out. The half bush may be simply replaced without carrying out the above steps.

TROUBLE SHOOTING

Minor problems can be solved without consulting a specialist. Below is a list of the more common problems with their possible causes and remedies.

PROBLEM

Motor does not start

POSSIBLE REASONS

- 1) No correct wiring
- 2) Motor failure or failure in the wiring supply

ACTION

- 1) Check fuses; if faulty, replace
- 2) Repair or replace part concerned

PROBLEM

The motor starts but then stops

POSSIBLE REASONS

- 1) Incorrect rotation
- 2) Screw obstruction
- 3) Output rate too high
- 4) Motor burnt out
- 5) Defective bearing or gear re-ducer
- 6) Outlet blocked

ACTION

- 1) Reverse poles
- 2) Change hanger bearings; if necessary clean whole screw feeder
- 3) Check ampmeter reading and output rate; if both are too high contact our Sales Office.
- 4) Discover reason and only then replace motor
- 5) Discover reason (see 2) - could be normal wear - replace part concerned
- 6) Free outlet

PROBLEM

Motor starts, but screw does not convey

POSSIBLE REASONS

- 1) Gear pinion or drive shaft sheared
- 2) Incorrect rotation
- 3) Bad outflow of material from silo due to faulty fluidization

ACTION

- 1) Discover reason, replace part concerned
- 2) Reverse poles
- 3) Improve outflow of material.

CHECK LIST IN CASE OF SCREW FEEDER TROUBLE

1) General questions Fault description

- a) Ask plant operator when and under which circumstances feeder stops. Does feeder start without problems after long periods of non-operation?
- b) Do weather conditions negatively influence feeder operation?
- c) If valve is fitted to feeder outlet check the center line of the valve shaft is parallel with the center line of the feeder, as would be fitted in normal circumstances.

Check valve fully opens.

Make sure feeder outlet valve is open when feeder starts and it only closes when feeder has already stopped.

If necessary disconnect valve actuator in open position.

2) Silo check

- a) Is the silo equipped with a deflecting or bridge breaking cone?
- b) Does silo include a fluidization system? If so how does it operate? Automatically at intervals while feeder is turned on? Manually for emergency in case of bridging?
- c) Is silo cone equipped with a vibrator or knocker? How does it work?

3) Electric equipment check

- a) Is a drop in voltage possible through the contemporary starting of various machines?
- b) Is the plant equipped with a generator?
- c) Check main supply of motor.
- d) Check electric motor is correctly wired and make sure wires are tightly fastened.
- e) Check adjustment of thermal cutout in the control panel and compare with data on the motor plate.
- f) Check motor rotation.
- g) Read amperage with feeder running empty, then with filled feeder starting, as well as with full feeder running.
- h) Check cross section of mains cables are suitable for the installed drive power.

4) Mechanical parts check

- a) Is breather plug of gear reducer functioning?
- b) Check outlet is free of crusts. Describe outlet (e.g. vertical or angular).
- c) Check weigh hopper vent is functioning correctly and check correct dimensioning of same.

5) Feeder check

- a) Are feeder parts correctly assembled? Do all inspection hatches point downwards?
- b) Does feeder bend? Stretch a string. If necessary additional supports must be fitted (every 3 to 5 metres to feet).
- c) Shut silo outlet valve. Empty feeder.
- d) Open inspection hatches. Check intermediate bearings are okay and correctly mounted.
- e) Turn feeder by hand using a spanner on the outlet end bearing shaft. If you don't feel any resistance and don't hear any grinding noise it is most certain that feeder is mechanically sound.
- f) Shut inspection hatches. Start feeder. Read amperage, voltage, cycles and screw r.p.m. with empty feeder running. Compare ammeter reading with motor plate data.
- g) Repeat starting procedure with feeder at full load and read amperage, voltage and cycles.

6) Material check

- a) Material description?
- b) Bulk density? (kg/dm³)
- c) Particle size? (µm/mm)
- d) Humidity? (%)
- e) Flowability? (make material slide down a metal plate by varying the angle from low to steep)
- f) Compressive material? (can you make a snowball?)
- g) Abrasive material? (does it hurt when rubbing it between your fingers?)

LUBRICATION OUTLET END BEARING

(with drive at inlet)

- Supplied with a long life grease filling the bearing does not require any further lubrication.

LUBRICATION INLET END BEARING

(with drive at outlet)

- Grease approx. every 200 working hours (depends on handled material). Substitute lubricant approx. every 7500 working hours.

LUBRICATION HANGER BEARING

- For most materials handled is not lubrication required. For those materials that require lubrication, grease every 10 working hours approx.

The trade marks of the lubricants are in alphabetical order which does not refer to the quality of the product. The list does not cover all available lubricants. Other quality makes can equally be used.

Table of lubricants
TRADE MARK
ESSO
MOBIL OIL
SHELL
TEXACO

LUBRICATION GEAR REDUCER

- L19, L17, M19 and M17 gear reduction units are supplied with long life oil filling. They are only equipped with a filling plug and the oil does not need to be topped up or changed.
- M12, M11 and M15 gear reduction units are supplied with a first oil filling and are equipped with oil level, outlet and breather plugs.
- First oil replacement after 1000 operating hours, then every 2500 operating hours approximately.

OIL	TRADE MARK
ENERGOL GR - XP220	BP
NL GEAR COMPOUND 220	CHEVRON
SPARTAN EP 220	ESSO
MOBILGEAR 630	MOBIL OIL
OMALA 220	SHELL
MEROPA 220	TEXACO

OIL QUANTITY FOR ONE FILLING (liters)			
Type	Motor size	a = 0°	a = 45°
M12	100-112	0.75	1
M12	132	1	1.50
M12	160	1.40	/
M11	132	1	1.50
M11	160	1.50	2.75
M15	160-180	4	6.50

The trade marks of the lubricants are in alphabetical order which does not refer to the quality of the product. The list does not cover all available lubricants. Other quality makes can equally be used.

- Table data refer to operation temperature between 0°C and 35°C. For temperatures higher than 35°C higher viscosity oils must be used, for temperatures lower than 0°C less viscous oils must be used.



SPARE PARTS

Page



Spare Parts.....	26
Tubular Screw Feeder Series Es With Three Hanger Bearings Steel Fabricated Parts.....	27 < 28
Tubular Screw Feeder Series Es Steel Fabricated Parts.....	29
Outlet Bearing Assembly Series XTA.....	30
Outlet Bearing Assembly Series XTB.....	31
Hanger Bearing Series XLR.....	32
Gear Box M17.....	33 < 35
Gear Box M12.....	36 < 37
Gear Box M11.....	38 < 39
Gear Box M15.....	40 < 41
Complete Motor.....	42
Safety.....	43

ADDRESS OF DEALER OR LOCAL SERVICE POINT

--

IDENTIFICATION

Refer to other code and/or to the serial number in the acknowledgment of order in the invoice and on the packaging to identify the equipment.

Type	1
Matr.	2
	OP.
 WAMGROUP	 WAM [®]

- 1) Order code.
- 2) Serial number.

EXAMPLE OF SERIAL NUMBER
CONTRAINDICATIONS TO USE

If the customer observes the normal caution (typical of this kind of machines) together with the indications contained in this manual, work is safe. These machines are NOT suitable for handling of foodstuff.

The machine must not be started before the machine itself, as well as the plant it is going to be installed in, have been declared in conformity with the European Directive 14/06/1982 (89/392/EEC).

It is the plant designer's / plant fitter's responsibility to design and install all necessary protection in order to avoid that breaking and/or yielding of the equipment or of parts of it might damage people and/or parts of the plant (e.g. adequate protection against falling down of the motor etc.). For the handling of products with the following characteristics the plant designer or fitter must provide for appropriate protection devices: dangerous, harmful when touched and/or inhaled, inflammable, explosive, infective.

ORDERING SPARE PARTS
A) Steel fabricated parts and bearing assemblies

Please indicate serial n^o. of the conveyor applied on each trough section, as well as page and item no. in this catalogue of the part concerned. Also indicate the required quantity of parts taking into consideration the minimum supply given in the price list.

B) Gear reduction units and electric motors

Instead of the screw serial n^o. indicate serial n^o. of gear reduction unit or of the electric motor and add information requested in paragraph A). Parts not included in price list cannot be supplied.

These are:

- 1) Standard parts if not included in kits
- 2) Item numbers in brackets, i.e. single parts included in kits.

Check minimum supply before making an order. General Supply Conditions are valid.

TUBULAR SCREW FEEDER SERIES ES WITH THREE HANGER BEARINGS STEEL FABRICATED PARTS

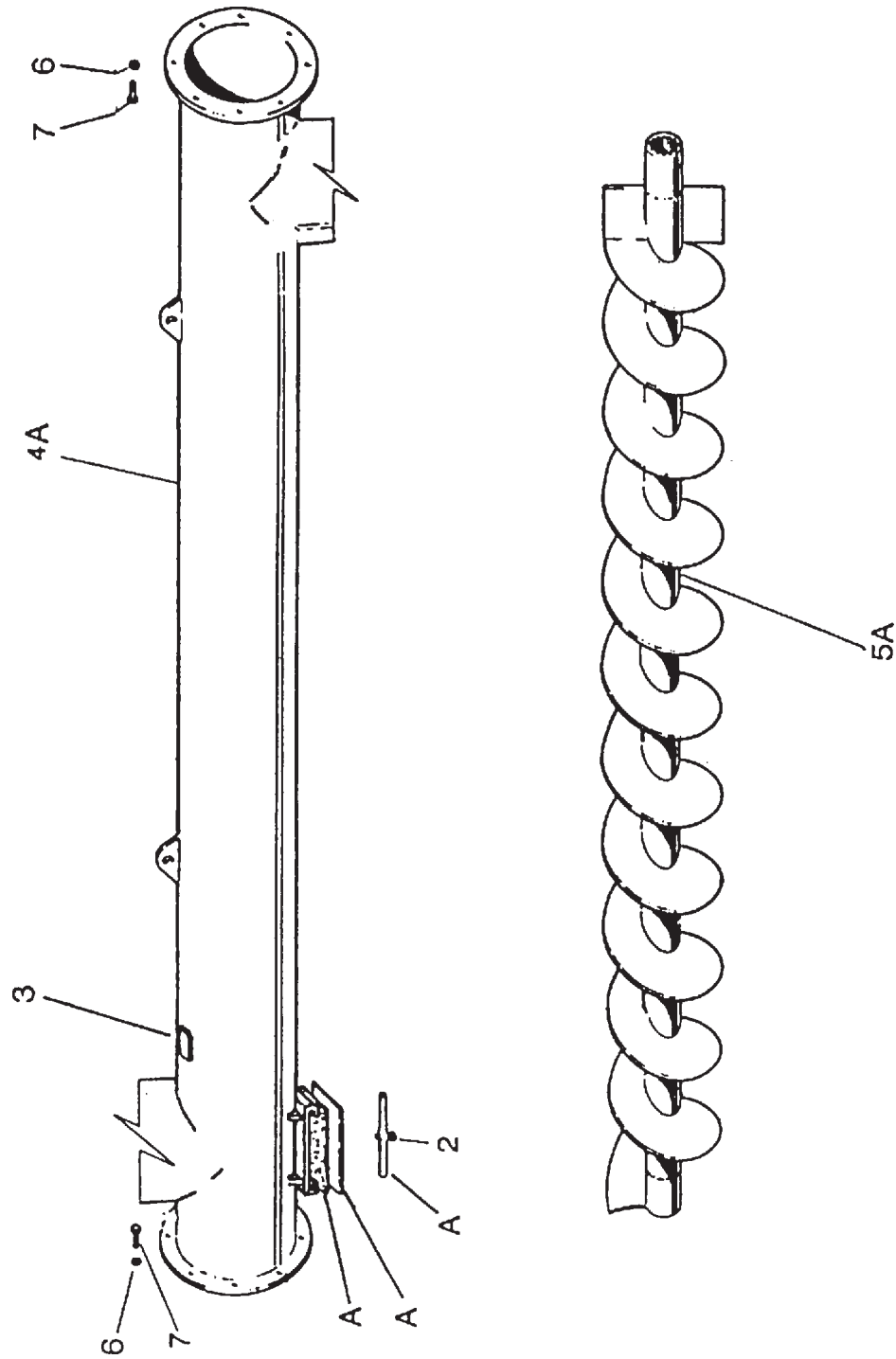

TUBULAR SCREW FEEDER SERIES ES WITH THREE HANGER BEARINGS STEEL FABRICATED PARTS

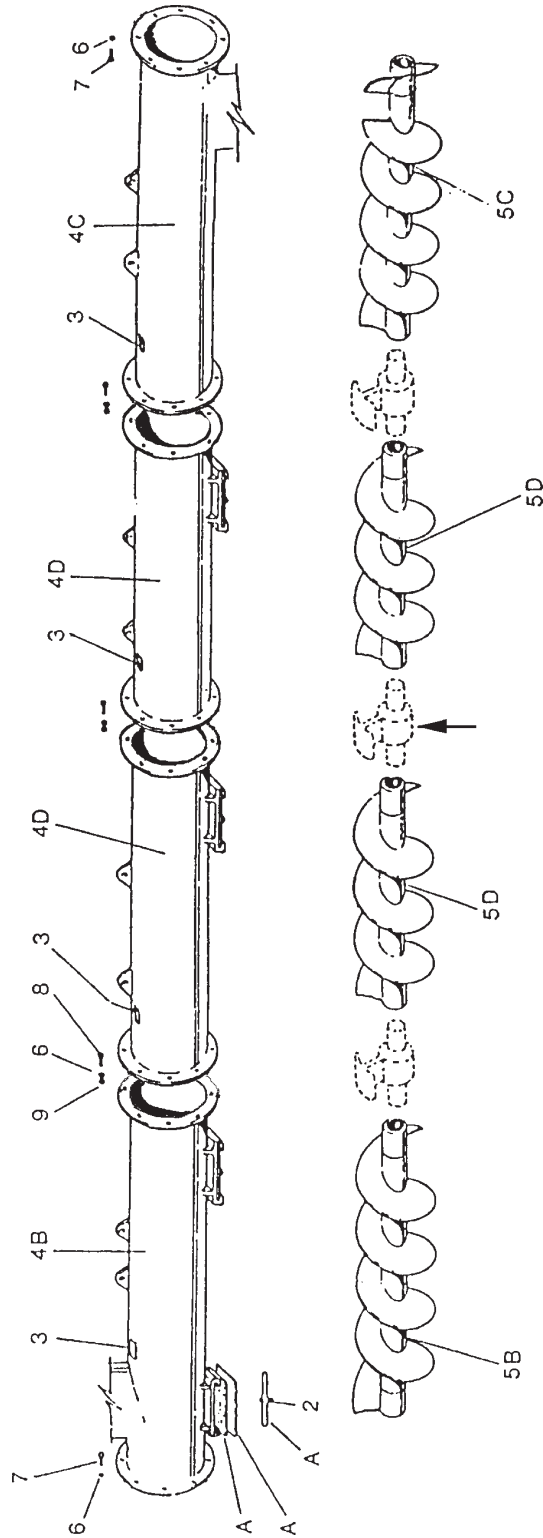

TUBULAR SCREW FEEDER SERIES ES STEEL FABRICATED PARTS

Item	Quantity	Standards	DESCRIPTION
A.1	1+X	ES 114-139	Inspection hatch Kit
A.2	1+X	ES 168-193	Inspection hatch kit
A.3	1+X	ES 219-273-323	Inspection hatch Kit
2	1	M16x55 DIN 558	Hexagonal bolt
3			Serial number
4A			External pipes (1 piece)
4B			External inlet pipe
4C			External outlet pipe
4D			External intermediate pipe
5A			Cpl. screw (1 piece)
5B			Cpl. inlet screw
5C			Cpl. outlet screw
5D			Cpl. intermediate screw
6.1	8+8X	Ø 8 DIN 6798	Washer (ES 114-139)
6.2	16+16X	Ø 10 DIN 6798	Washer (ES 168...323)
7.1	8	M8 x25 DIN 558	Hexagon. bolt (ES 114-139)
7.2	16	M10x30 DIN 558	Hexagon. bolt (ES 168...323)
8.1	4X	M8x35 DIN 558	Hexagon. bolt (ES 114-139)
8.2	8X	M10x40 DIN 558	Hexagon. bolt (ES 168...273)
8.3	8X	M10x50 DIN 558	Hexagon. bolt (ES 323)
9.1	4X	M8 DIN 558	Hexagon. bolt (ES 114-139)
9.2	8X	M8 DIN 558	Hexagon. bolt (ES 168...323)

OUTLET BEARING ASSEMBLY SERIES XTA

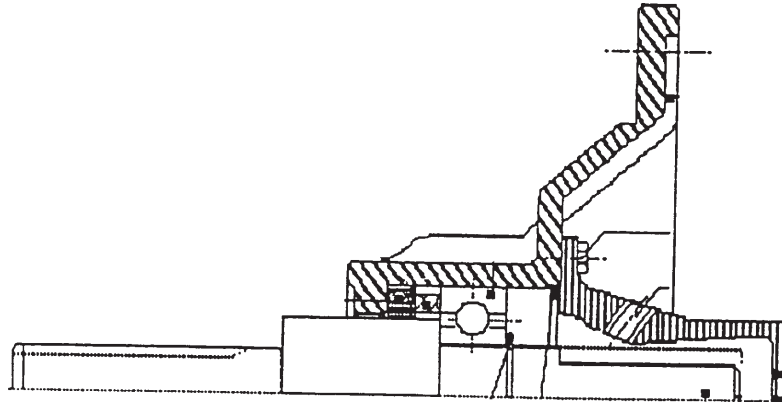

Diameter	Part Number
114 mm - 4"	XTA.00.ES0.AO1
168 mm - 6"	XTA.00.ES1.AO1
219 mm - 8"	XTA.00.ES3.AO1
273 mm - 10"	XTA.00.ES4.AO1
323 mm - 12"	XTA.00.ES5.AO1

OUTLET BEARING ASSEMBLY SERIES XTB

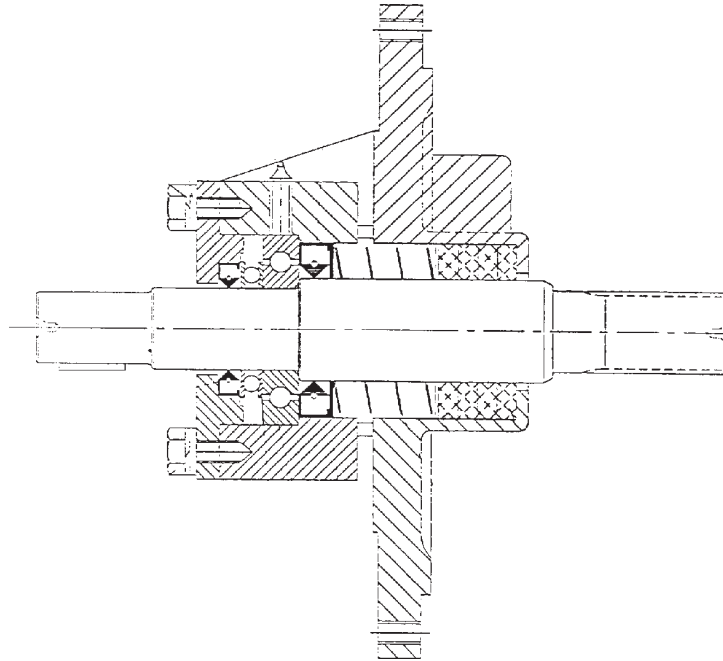

Only with drive unit mounted at outlet end !

Diameter	Part Number
114 mm - 4"	XTB.25.ES0.B12
168 mm - 6"	XTB.35.ES1.B12
219 mm - 8"	XTB.35.ES3.B12
273 mm - 10"	XTB.35.ES4.B12
323 mm - 12"	XTB.35.ES5.B12

HANGER BEARING SERIES XLR

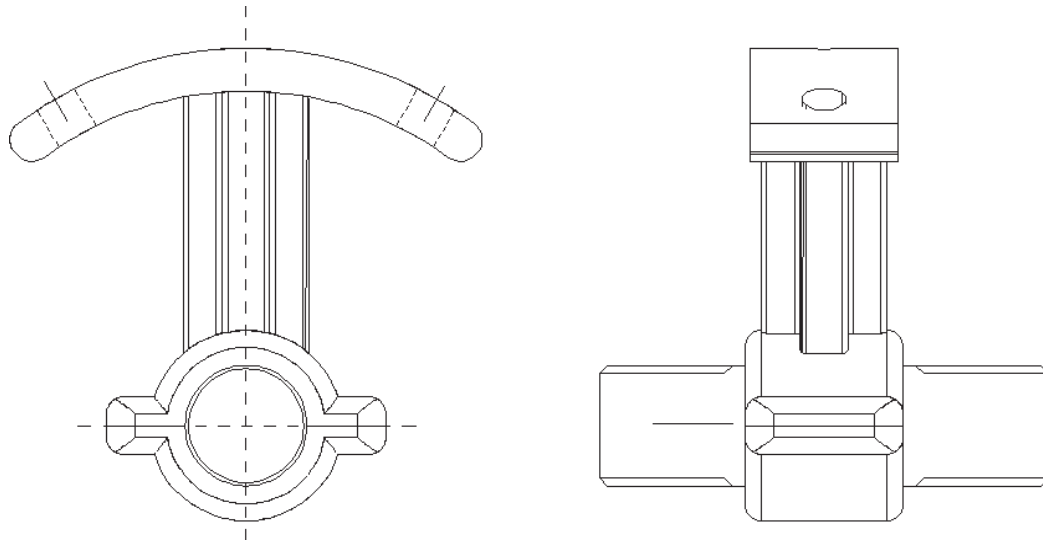

Diameter	Part Number
114 mm - 4"	XLR.028B010T44
168 mm - 6"	XLR.040B015T44
219 mm - 8"	XLR.040B020T44
273 mm - 10"	XLR.040B025T44
323 mm - 12"	XLR.040B030T44

GEAR REDUCTION HEAD SERIES M17 with incorporated end bearing

- for IEC and NEMA motors: 0.55 kW - 0.75 kW - 1.1 kW - 1.5 kW - 2.2 kW - 3 kW - 4 kW - 5.5 kW

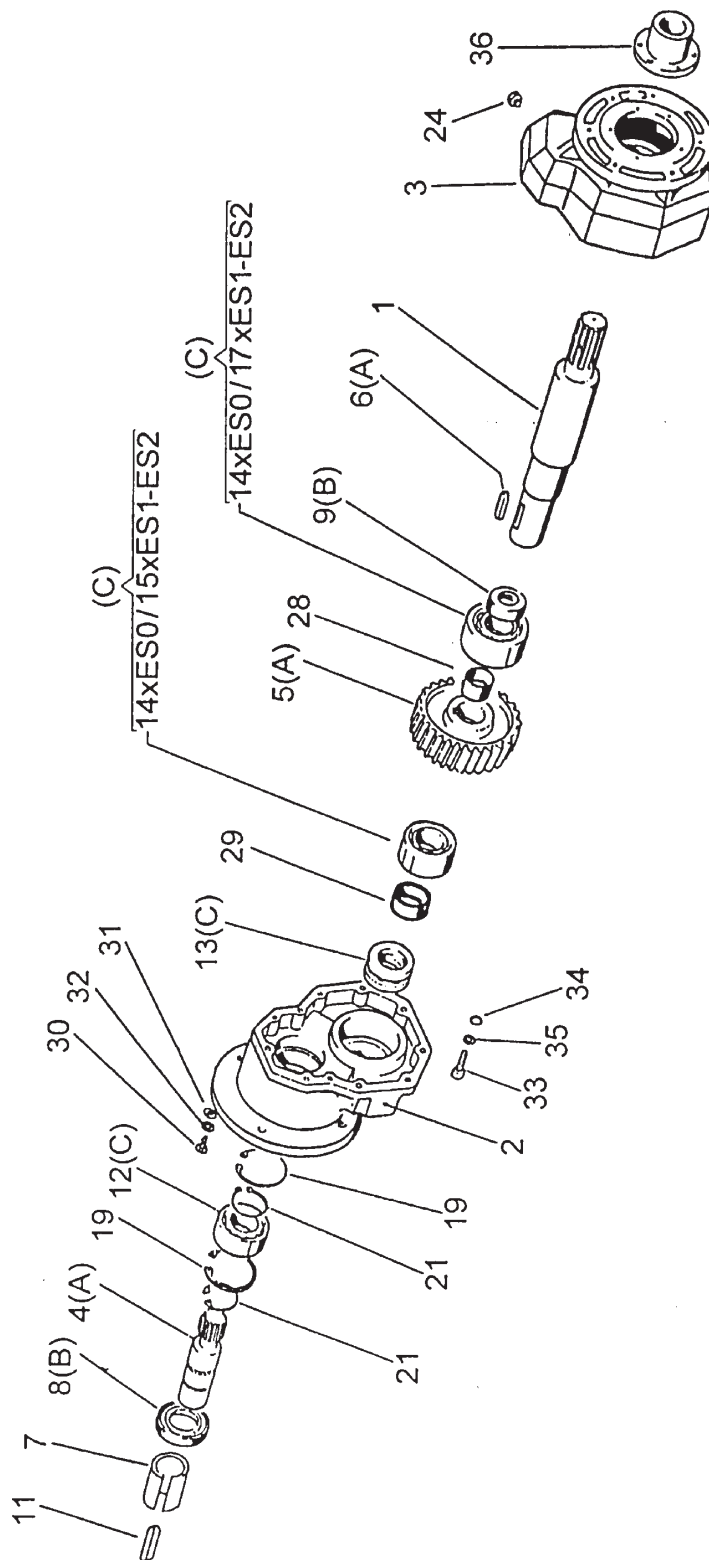

SPARE PARTS GEAR BOX M17

GEAR REDUCTION HEAD SERIES M17 with incorporated end bearing - for IEC and NEMA motors

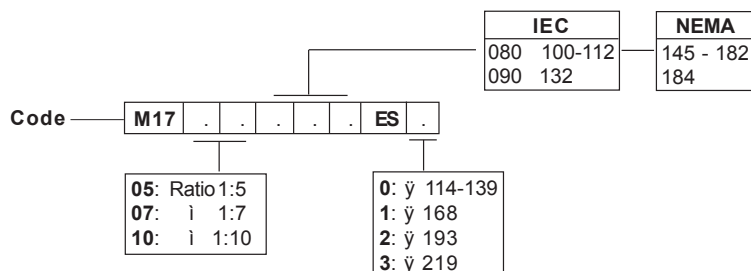

Item	Quantity	Standards	DESCRIPTION
1	1		Shaft ESO
1b	1		Shaft ES 1-2-3
2a	1		Casing motor end (80-90)
2b	1		Casing motor end (100-112)
2c	1		Casing motor end (132)
3a	1		Casing screw end ESO
3b	1		Casing screw end ES1
3c	1		Casing screw end ES2
3d	1		Casing screw end ES1 (132)
3e	1		Casing screw end ES2 (132)
3f	1		Casing screw end ES3 (132)
Aa	1		Gear Kit 1:5 (80-90)
(4)	1		Pinion shaft
(5)	1		Cog wheel
(6)	1	8x7x25 DIN 6885	Parallel Key
Ab	1		Gear Kit 1:5 (112)
(4)	1		Pinion shaft
(5)	1		Cog wheel
(6)	1	8x7x20 DIN 6885	Parallel Key
Ac	1		Gear Kit 1:5 (132)
(4)	1		Pinion shaft
(5)	1		Cog wheel
(6)	1	8x7x20 DIN 6885	Parallel Key
Ad	1		Gear kit 1:7 (80-90)
(4)	1		Pinion shaft
(5)	1		Cog wheel
(6)	1	8x7x20 DIN 6885	Parallel Key
Ae	1		Gear Kit 1:7 (112)
(4)	1		Pinion shaft
(5)	1		Cog wheel
(6)	1	8x7x20 DIN 6885	Parallel Key

Item	Quantity	Standards	DESCRIPTION
Af	1		Gear Kit 1/10 (80-90)
(4)	1		Pinion shaft
(5)	1		Cog wheel
(6)	1	8x7x25 DIN 6885	Parallel Key
Ag	1		Gear Kit 1/10 (112)
(4)	1		Pinion shaft
(5)	1		Cog wheel
(6)	1	8x7x25 DIN 6885	Parallel Key
Ba	1		Internal seal Kit ESO (80-90)
(8)	1	DIN 3760-NB	Shaft seal
(9)	1	DIN 3760-NB	Shaft seal
Bb	1		Internal seal Kit ESO (100-112)
(8)	1	DIN 3760-NB	Shaft seal
(9)	1	DIN 3760-NB	Shaft seal
Bc	1		Internal seal Kit ESO (100-112)
(8)	1	DIN 3760-NB	Shaft seal
(9)	1	DIN 3760-NB	Shaft seal
Bd	1		Internal seal Kit ES1-2 (100-112)
(8)	1	DIN 3760-NB	Shaft seal
(9)	1	DIN 3760-NB	Shaft seal
Be	1		Internal seal Kit ES1-2-3 (132)
(8)	1	DIN 3760-NB	Shaft seal
(9)	1	DIN 3760-NB	Shaft seal
	1		Bearing Kit ESO (80-90)
(12)	1	DIN 625	Bearing
(13)	2	DIN 711	Bearing
(14)	1	DIN 625	Bearing
Cb	1		Bearing Kit ESO (100-112)
(12)	1	DIN 625	Bearing
(13)	2	DIN 711	Bearing
(14)		DIN 625	Bearing

SPARE PARTS GEAR BOX M17

GEAR REDUCTION HEAD SERIES M17 with incorporated end bearing - for IEC and NEMA motors

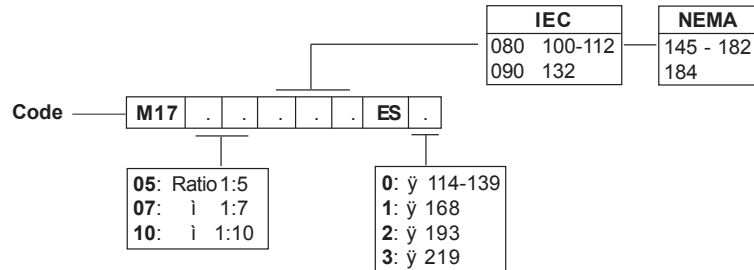

Item	Quantity	Standards	DESCRIPTION
Cd	1		Bearing Kit ES1-2 (80-90)
(12)	1	DIN 625	Bearing
(13)	1	DIN 711	Bearing
(15)	1	DIN625	Bearing
(17)	1	DIN 625	Bearing
Ce	1		Bearing Kit ES1-2 (100-112)
(12)	1	DIN 625	Bearing
(13)	1	DIN 711	Bearing
(15)	1	DIN 625	Bearing
(17)	1	DIN 625	Bearing
Cf	1		Bearing Kit ES1-2-3 (132)
(12)	1	DIN 625	Bearing
(13)	1	DIN 711	Bearing
(15)	1	DIN625	Bearing
(17)	1	DIN 625	Bearing
24	1	3/8"	Oil plug
19a	2	Ø 68 DIN 472	Retaining ring for bore (80-90)
19b	2	Ø 80 DIN 472	Retaining ring for bore (100-112)
19c	2	Ø 95 DIN 472	Retaining ring for bore (132)
21a	2	Ø 40 DIN 471	Retaining ring for shaft (80-90)
21b	2	Ø 50 DIN 471	Retaining ring for shaft (100-112)
21c	2	Ø 66 DIN 471	Retaining ring for shaft (132)
28	1		Spacer ES1 - ES2
29	1	Ø 30x42x1DIN 988	Retaining ring
30a	4	M 10x25 DIN 933	Hexagonal bolt (80-90)
30b	4	M12x30 DIN 933	Hexagonal bolt (100-112-132)
31a	4	Ø 10 DIN 125A	Beveled washer (80-90)
31b	4	Ø 12 DIN 125A	Beveled washer (100-112-132)
32a	4	Ø 10 DIN 7980	Elastic washer (80-90)
32b	4	Ø 12 DIN 7980	Elastic washer (100-112-132)
33a	9	M8x30 DIN 912	Hexagonal socket bolt (80-90)
33b	9	M8x75 DIN 912	Hexagonal socket bolt (100-112-132)
34	9	Ø 8 DIN 125A	Beveled washer
35	9	Ø 8 DIN 7980	Elastic washer
7	1		Adapter sleeve (80)
11	1		Parallel Key (80)
36a	1		Shaft sealing unit ES0
36b	1		Shaft sealing unit ES1-2-3

GEAR REDUCTION HEAD SERIES M12 with incorporated end bearing

- for IEC and NEMA motors: 3 kW - 4 kW - 5.5 kW - 7.5 kW - 9.2 kW - 11 kW

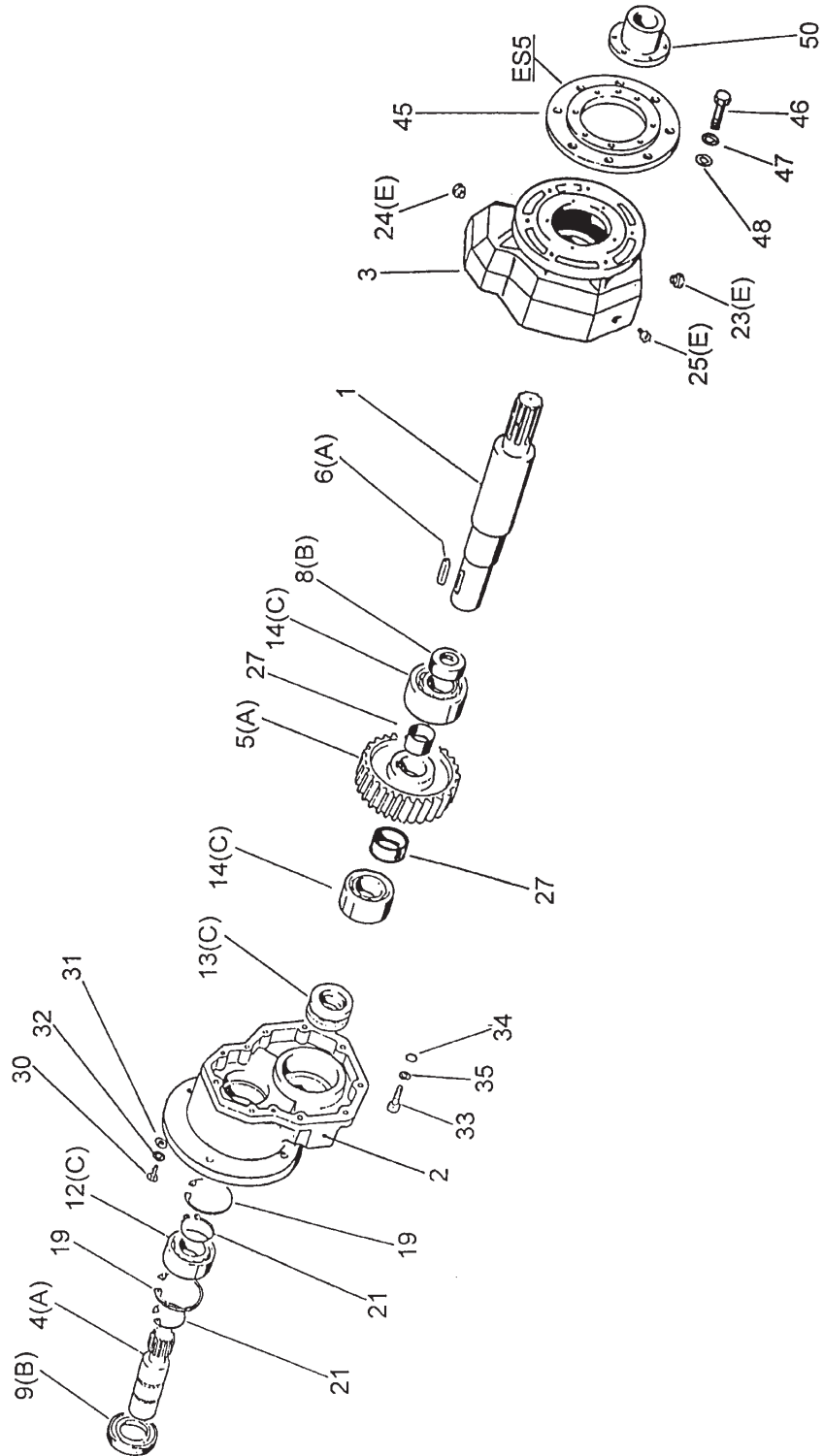

SPARE PARTS GEAR BOX M12

GEAR REDUCTION HEAD SERIES M12 with incorporated end bearing - for IEC and NEMA motors

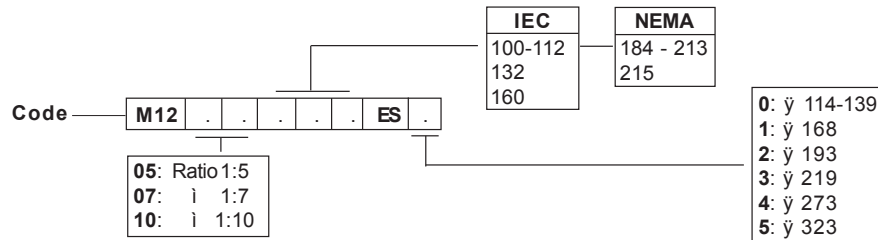

Item	Quantity	Standards	DESCRIPTION
1	1		Shaft
2a	1		Casing motor end (100-112)
2b	1		Casing motor end (132)
2c	1		Casing motor end (160)
3a	1		Casing screw end ES1
3b	1		Casing screw ES2
3c	1		Casing screw end ES3-ES5
3d	1		Casing screw end ES4
Aa	1		Gear Kit 1/5 (112)
(4)	1		Pinion shaft
(5)	1		Cog wheel
(6)	1		Parallel Key
Ab	1		Gear Kit 1/5 (132)
(4)	1		Pinion shaft
(5)	1		Cog wheel
(6)	1		Parallel Key
Ac	1		Gear Kit 1/5 (160)
(4)	1		Pinion shaft
(5)	1		Cog wheel
(6)	1		Parallel Key
Ad	1		Gear Kit 1/6 (112)
(4)	1		Pinion shaft
(5)	1		Cog wheel
(6)	1		Parallel Key
Ae	1		Gear Kit 1/6 (132)
(4)	1		Pinion shaft
(5)	1		Cog wheel
(6)	1		Parallel Key

Item	Quantity	Standards	DESCRIPTION
Af	1		Gear Kit 1/7 (132)
(4)	1		Pinion shaft
(5)	1		Cog wheel
(6)	1		Parallel Key
Ah	1		Gear Kit 1/7 (132)
(4)	1		Pinion shaft
(5)	1		Cog wheel
(6)	1		Parallel Key
Ai	1		Gear Kit 1/10 (112)
(4)	1		Pinion shaft
(5)	1		Cog wheel
(6)	1		Parallel Key
Al	1		Gear Kit 1/10 (132)
(4)	1		Pinion shaft
(5)	1		Cog wheel
(6)	1		Parallel Key
Ba	1		Internal seal Kit (112)
(8)	1	DIN 3760-NB	Shaft seal
(9)	1	DIN 3760-NB	Shaft seal
Bb	1		Internal seal Kit (132-160)
(8)	1	DIN 3760-NB	Shaft seal
(9)	1	DIN 3760-NB	shaft seal
Ca	1		Bearing Kit (110-112)
(12)	1	DIN 625	Bearing
(13)	1	DIN 711	Bearing
(14)	1	DIN625	Bearing
Cb	1		Bearing Kit (132-160)
(12)	1	DIN 625	Bearing
(13)	1	DIN 711	Bearing
(14)	1	DIN625	Bearing

Item	Quantity	Standards	DESCRIPTION
E	1		Oil plug Kit
(23)	1	3/8"	Oil outlet plug
(24)	1	3/8"	Breather plug
(25)	1	3/8"	Oil level plug
19a	2	Ø 80 DIN 472	Retaining ring for bore 110-112
19b	2	Ø 95 DIN 472	Retaining ring for bore 132-160
21a	2	Ø 50 DIN 471	Retaining ring for shaft 110-112
21b	2	Ø 60 DIN 471	Retaining ring for shaft 132-160
27	2		Spacer
30	4	M 12x30 DIN 933	Hexagonal bolt
31	4	Ø12 DIN 125A	Beveled washer
32	4	Ø 12 DIN 7980	Elastic washer
33	9	M8x75 DIN 912	Hexagonal socket bolt
34	9	Ø 8 DIN 125A	Beveled washer
35	9	Ø 8 DIN 7980	Elastic washer
45	1		Flange
46	8	M10x35 DIN 933	Hexagonal bolt
47	8	Ø10 DIN 125A	Beveled washer
48	8	Ø 10 DIN 7980	Elastic washer
50	1		Shaft sealing unit

ES - TUBULAR CEMENT SCREWS CONVEYORS

SPARE PARTS GEAR BOX M11

GEAR REDUCTION HEAD SERIES M11 with incorporated end bearing
- for IEC and NEMA motors: 5.5 kW - 7.5 kW - 9.2 kW - 11 kW - 15 kW

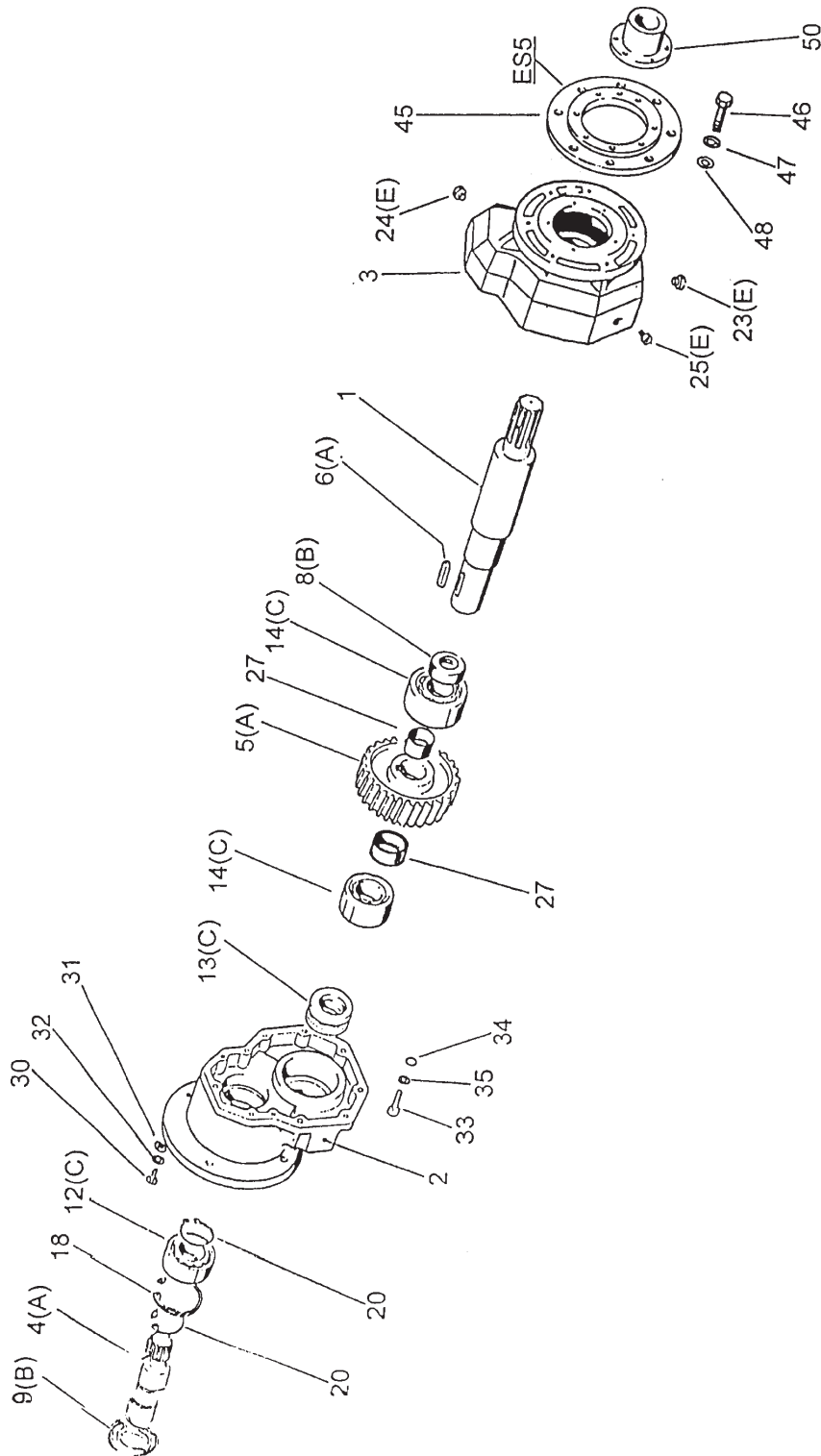

GEAR REDUCTION HEAD SERIES M11 with incorporated end bearing - for IEC and NEMA motors

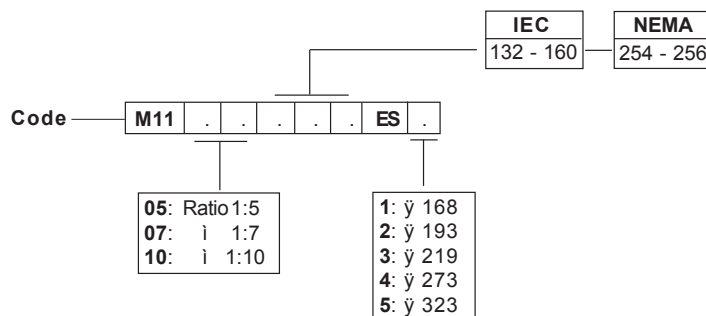

Item	Quantity	Standards	DESCRIPTION
1	1		Shaft
2b	1		Casing motor end (132)
2c	1		Casing motor end (160)
3a	1		Casing screw end ES1
3b	1		Casing screw end ES2
3c	1		Casing screw end ES3-ES5
3d	1		Casing screw ES4
Ab	1		Gear Kit 1/5 (160)
(4)	1		Pinion shaft
(5)	1		Cog wheel
(6)	1	12x8x35 DIN6885	Parallel Key
Ac	1		Gear Kit 1/6 (132)
(4)	1		Pinion shaft
(5)	1		Cog wheel
(6)	1	12x8x35 DIN6885	Parallel Key
Ad	1		Gear Kit 1/6 (160)
(4)	1		Pinion shaft
(5)	1		Cog wheel
(6)	1	12x8x35 DIN6885	Parallel Key
Ae	1		Gear Kit 1/7 (132)
(4)	1		Pinion shaft
(5)	1		Cog wheel
(6)	1	12x8x35 DIN6885	Parallel Key
Af	1		Gear Kit 1/7 (160)
(4)	1		Pinion shaft
(5)	1		Cog wheel
(6)	1	12x8x35 DIN6885	Parallel Key

Item	Quantity	Standards	DESCRIPTION
Ag	1		Gear Kit 1/10 (132)
(4)	1		Pinion shaft
(5)	1		Cog wheel
(6)	1		Parallel Key
Ah	1		Gear Kit 1/10 (160)
(4)	1		Pinion shaft
(5)	1		Cog wheel
(6)	1		Parallel Key
B	1		Internal seals Kit
(4)	1	DIN 3760-NB	Shaft seal
(5)	1	DIN 3760-NB	Shaft seal
C	1		Bearing Kit
(12)	1	DIN 625	Bearing
(13)	1	DIN 711	Bearing
(14)	2	DIN 625	Bearing
E	1		Oil plugs Kit
(23)	1	3/8"	Oil outlet plug
(24)	1	3/8"	Breather plug
(25)	1	3/8"	Oil level plug
18	1	Ø 95 DIN 472	Retaining ring for bore
20	2	Ø 60 DIN 471	Retaining ring for shaft
27	2		Spacer
30	4	M12x30 DIN 933	Hexagonal bolt
31	4	Ø 12 DIN 125A	Beveled washer
32	4	Ø 12 DIN 7980	Elastic washer
33	9	M 8x30 DIN 912	Hex.socket bolt
34	9	M 8 DIN 125A	Beveled washer
35	9	M 8 DIN 7980	Elastic washer
45	1		Flange
46	8	M 10x35 DIN 933	Hexagonal bolt
47	8	Ø 10 DIN 125A	Beveled washer
48	8	Ø 10 DIN 7980	Elastic washer
50	1		Shaft sealing unit

ES - TUBULAR CEMENT SCREWS CONVEYORS

SPARE PARTS GEAR BOX M15

GEAR REDUCTION HEAD SERIES M15 with incorporated end bearing
- for IEC and NEMA motors: 11 kW - 15 kW - 18.5 kW - 22 kW - 30 kW

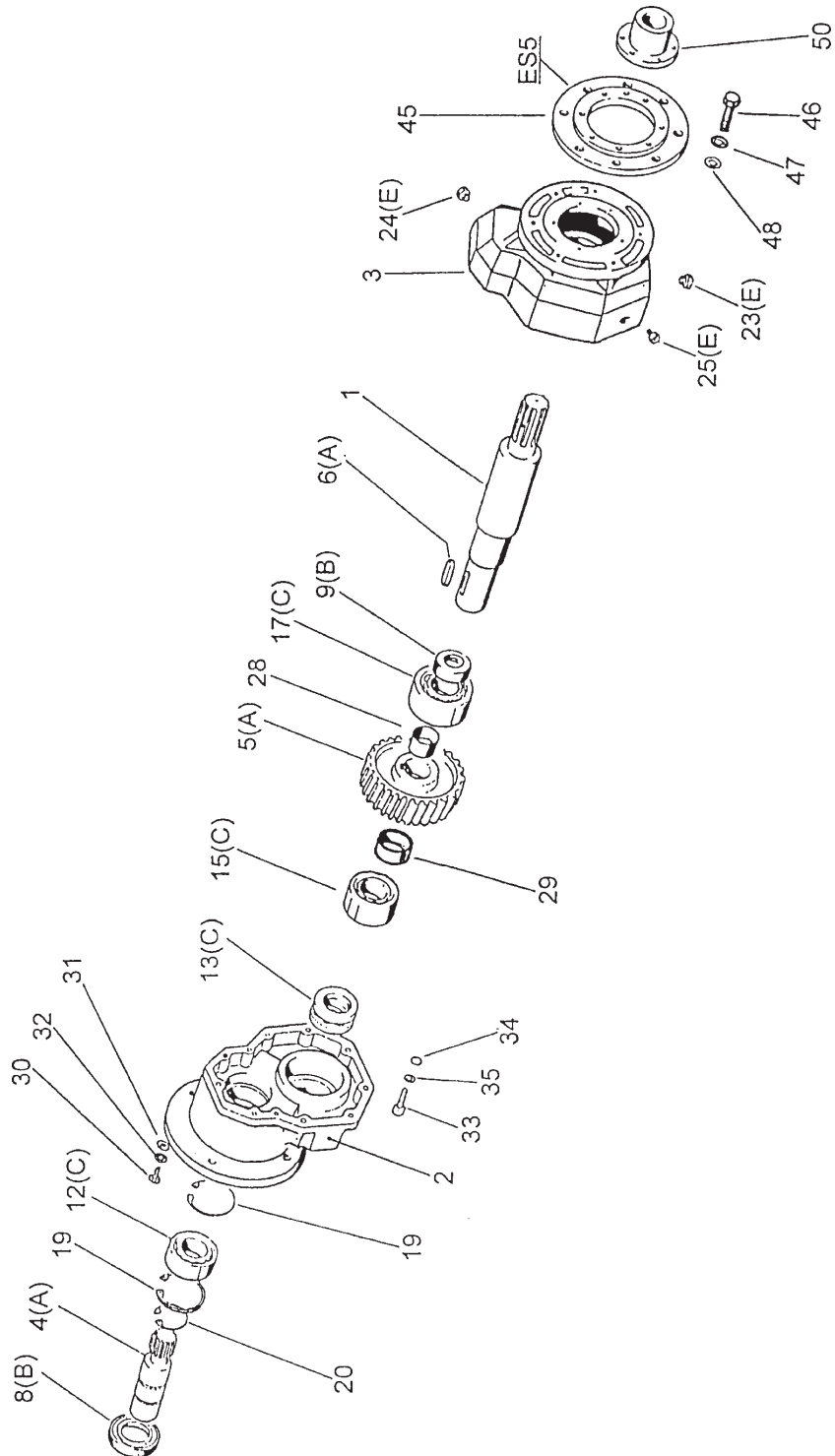

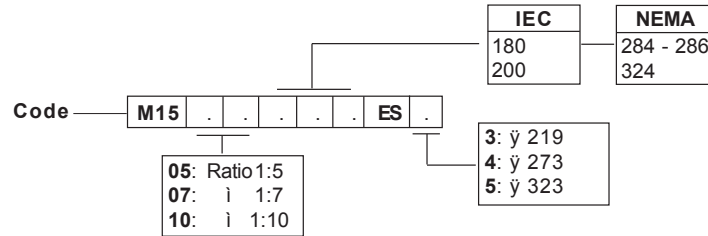
GEAR REDUCTION HEAD SERIES M15 with incorporated end bearing - for IEC and NEMA motors

Item	Quantity	Standards	DESCRIPTION
1	1		Shaft
2b	1		Casing motor end (160-180)
2c	1		Casing motor end (200)
3a	1		Casing screw end ES3-ES5
3b	1		Casing screw ES4
Aa	1		Gear Kit 1/5 (160)
(4)	1		Pinion shaft
(5)	1		Cog wheel
(6)	1	14x9x40 DIN6885	Parallel Key
Ab	1		Gear Kit 1/5 (180)
(4)	1		Pinion shaft
(5)	1		Cog wheel
(6)	1	14x9x40 DIN6885	Parallel Key
Ac	1		Gear Kit 1/6 (160)
(4)	1		Pinion shaft
(5)	1		Cog wheel
(6)	1	14x9x40 DIN6885	Parallel Key
Ad	1		Gear Kit 1/6 (180)
(4)	1		Pinion shaft
(5)	1		Cog wheel
(6)	1	14x9x40 DIN6885	Parallel Key
Ae	1		Gear kit 1/7 (160)
(4)	1		Pinion shaft
(5)	1		Cog wheel
(6)	1	14x9x40 DIN6885	Parallel Key
Af	1		Gear Kit 1/7 (180)
(4)	1		Pinion shaft
(5)	1		Cog wheel
(6)	1	14x9x40 DIN6885	Parallel

Item	Quantity	Standards	DESCRIPTION
E	1		Oil plug Kit
(23)	1	3/8"	Oil outlet plug
(24)	1	3/8"	Breather plug
(25)	1	3/8"	Oil level plug
19a	2	Ø 110DIN 472	Retaining ring for bore (160-180)
19b	2	Ø 125 DIN 472	Retaining rin for bore (200)
20a	1	Ø 70DIN 471	Retaining ring for Shaft (160-180)
20b	1	Ø 80 DIN 471	Retaining ring for shaft (200)
28	1		Spacer
29	1		Spacer
30	4	M16x40 DIN 933	Hexagonal bolt
31	4	Ø 16 DIN 125A	Beveled washer
32	4	Ø16 DIN 7980	Elastic washer
33	14	M 10x75 DIN 912	Hexagonal socket bolt
34	14	Ø 10 DIN 125A	Beveled Washer
35	14	Ø 10 DIN 7980	Elastic washer
45	1		Flange
46	8	M10x35 DIN 933	Hexagonal bolt
47	8	Ø10DIN 125A	Beveled washer
48	8	Ø 10SDIN 7980	Elastic washer
50	1		Shaft sealing unit

Item	Quantity	Standards	DESCRIPTION
Ag	1		Gear Kit 1/7 (200)
(4)	1		Pinion shaft
(5)	1		Cog wheel
(6)	1	14x9x40 DIN6885	Parallel Key
Ah	1		Gear kit 1/10 (160)
(4)	1		Pinion shaft
(5)	1		Cog wheel
(6)	1	14x9x40 DIN6885	Parallel Key
Ai	1		Gear kit 1/10 (180)
(4)	1		Pinion shaft
(5)	1		Cog wheel
(6)	1	14x9x40 DIN6885	Parallel key
Al	1		Gear Kit 1/10 (200)
(4)	1		Pinion shaft
(5)	1		Cog wheel
(6)	1	14x9x40 DIN6885	Parallel Key
Ba	1		Internal seal Kit (160-180)
(8)	1	DIN 3760-NB	Shaft seal
(9)	1	DIN 3760-NB	Shaft seal
Bb	1		Internal seal Kit (200)
(8)	1	DIN 3760-NB	Shaft seal
(9)	1	DIN 3760-NB	Shaft seal
Ca	1		Bearing Kit (160-180)
(12)	1	DIN 625	Bearing
(13)	1	DIN 711	Bearing
(15)	1	DIN 625	Bearing
(17)	1	DIN 625	Bearing
Cb	1		Bearing Kit (200)
(12)	1	DIN 625	Bearing
(13)	1	DIN 711	Bearing
(15)	1	DIN 625	Bearing
(17)	1	DIN 625	Bearing

SPARE PARTS

COMPLETE MOTOR

Code — **M** **0 4** **5**

4 = CLASS.F. IP55

NEMA	IEC	kW
143	0900M	1.1
145	0900L	1.5
182	100LR	2.2
-	100LH	3.0
184	1120M	4.0
213	1320S	5.5
215	1320M	7.5
-	1320L	9.2
254	1600M	11.0
256	1600L	15.0
282	1800M	18.5

W = 208 - 230 / 460V 60Hz
Q = 575V 60Hz
E = 220/380V 50Hz

Poles	
02	3600 RPM
04	1800 RPM
06	1200 RPM

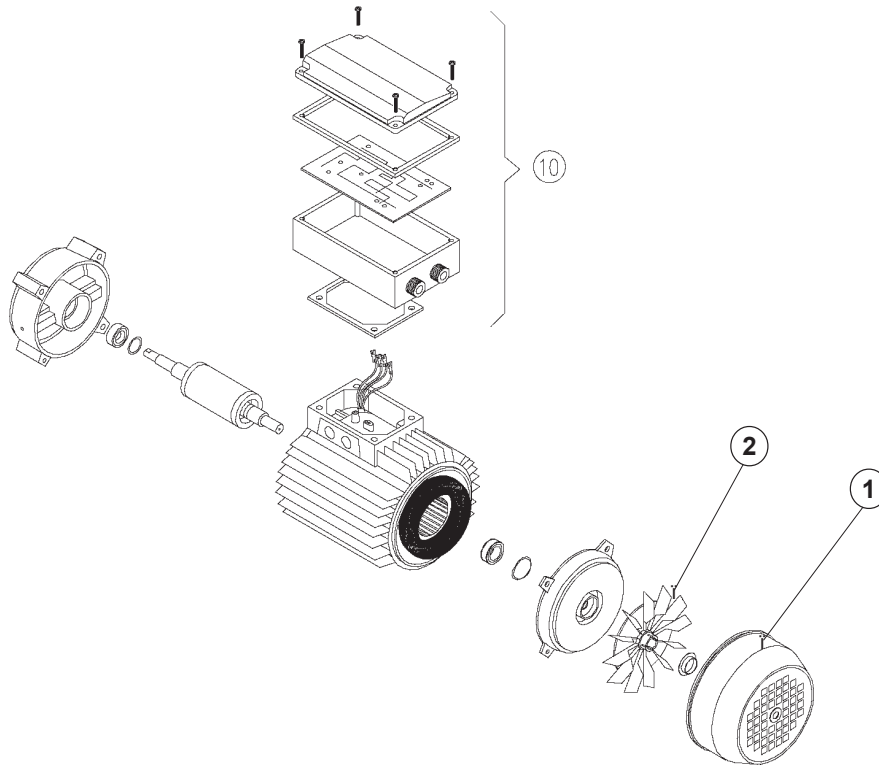

Item	Quantity	Standards	DESCRIPTION
1	1		Fan guard
2	1		Fan
			Rear flange
			Fan bearing
			Casing
			Stator
			Rotor
			Front bearing
			Front flange
10	1		Terminal box



WARNING AND SAFETY INSTRUCTIONS

NOTE TO USERS: Do not attempt any maintenance or repairs of the conveyor until power has been locked out and tagged out. Control Stored Energy: Use safety blocks between dangerous parts that could move and injure.

Safety must be considered a basic factor in machinery operation at all times. Most accidents are the result of carelessness or negligence. The following safety instructions are basic guidelines and should be considered as minimum provisions. Additional information shall be obtained by the purchaser from other sources, including the American Society of Mechanical Engineers, Standard ANSI B20.1, Standard ANSI B15.1, Standard ANSI A12.1 Standard ANSI MH4.7 and Standard ANSI Z244.

WAM, Inc. does not install equipment, consequently it is the responsibility of the contractor, installer, owner and user to install, maintain and operate the conveyor, components and assemblies in such a manner as to comply with the William-Steiger Occupational Safety and Health Act and with all state and local laws and ordinances and the American National Standard Institute (ANSI) safety code.

In order to avoid an unsafe or hazardous condition, the assemblies or parts must be installed and operated in accordance with the following minimum provisions.

1. Conveyors, and all other rotating and vibrating equipment (**hereafter referred to as equipment**) shall not be operated unless all covers and/or guards for the equipment and drive unit are in place. If the equipment is to be opened for inspection cleaning, maintenance or observation, the electric power to the motor driving the conveyor must be LOCKED OUT and TAGGED OUT in such a manner that the equipment cannot be restarted by anyone; however remote from the area, until equipment cover or guards and drive guards have been properly replaced.
2. If the equipment must have an open housing as a condition of its use and application, the entire equipment is then to be guarded by a railing or fence in accordance with ANSI standard B20.1-1993, with special attention given to section 6.12.
3. Feed openings for shovel, front loaders or other manual or mechanical equipment shall be constructed in such a way that the equipment opening is covered by a grating. If the nature of the material is such that a grating cannot be used, then the exposed

1. section of the equipment is to be guarded by a railing or fence and there shall be a warning sign posted.
2. Do not attempt any maintenance or repairs of the equipment until power has been LOCKED OUT and TAGGED OUT.
3. Control stored energy: Use safety blocks between dangerous parts that could move and injure. Always operate conveyor in accordance with these instructions and those contained on the caution labels affixed to the equipment.
4. Do not place hands or feet in the equipment.
5. Never walk on equipment covers, grating or guards.
6. Do not use equipment for any purpose other than that for which it was intended.
7. Do not poke or prod material into the equipment with a bar or stick inserted through the openings.
8. Keep area around equipment drive and control station free of debris and obstacles.
9. Always regulate the feeding of material into the unit at a uniform and continuous rate.
10. Do not attempt to clear jammed equipment until power has been LOCKED OUT and TAGGED OUT.
11. Do not attempt field modification of equipment or components.
12. Equipment is not normally manufactured or designed to handle materials that are hazardous to personnel. These materials which are hazardous include those that are explosive, flammable, toxic, or otherwise dangerous to personnel. Equipment may be designed to handle these materials. Equipment is not manufactured or designed to comply with local, state or federal codes for unfired pressure vessels. If hazardous materials are to be conveyed or if the equipment is to be subjected to internal or external pressure, WAM, Inc. should be consulted prior to any modifications.

WAM, Inc. insists that disconnecting and locking out and tagging out the power to the motor driving the unit provides this only real protection against injury. Secondary safety devices are available; however, the decision as to their need and the type required must be made

by the owner-assembler as we have no information regarding plant wiring, plant environment, the interlocking of the equipment with other equipment, extent of plant automation, etc. Other devices should not be used as a substitute for locking out the power prior to removing guards or covers. We caution that use of the secondary devices may cause employees to develop a false sense of security and fail to lock out power before removing covers or guards. This could result in a serious injury should the secondary device fail or malfunction.

There are many kinds of electrical devices for interlocking of equipment and equipment systems such that if one item of equipment in a system or process is stopped other equipment feeding it, or following it can also be automatically stopped.

Electrical controls, machinery guards, railings, walkways, arrangement of installation, training of personnel, etc. are necessary ingredients for a safe working place. It is the responsibility of the contractor, installer, owner and user to supplement the materials and services furnished with these necessary items to make the equipment installation comply with the law and accepted standards.

Equipment inlet and discharge openings are designed to connect to other equipment or machinery so that the flow of material into and out of the equipment is completely enclosed.

One or more caution signs as illustrated below are attached to equipment housings and equipment covers. Please order replacement caution labels should the labels attached to this equipment become illegible. Use Conveyor or Equipment Manufacturers Association (CEMA) iSafety Label Brochure and Placement Guidelines (#201). CEMA can be contacted at: : www.cemanet.org , or may be written to at:

CEMA
6724 Lone Oak Blvd.
Naples, FL 34109

WAM, Inc. also provides this information to our customers free of charge when requested.

The label shown below has been reduced in size. The actual size is printed next to the label. For more detailed instructions and information please request a free copy of our iScrew Conveyor Safety, Installation, Operation, Maintenance Instructions.†



Actual Size is 5 1/2" Wide x 2 1/2" High



Actual Size is 5 1/2" Wide x 2 1/2" High



Actual Size is 5 1/2" Wide x 2 1/2" High